



# ESLTOPJX00LR



## Fulham's Link: an external PIR Smart Link+

- PIR occupancy detection sensor
- Built in Daylight Harvesting
- Plug and play: RJ12 connection
- Compatible only with Fulham's connected devices (EliteControls Workhorse)
- FCC ID:2AJ9LESLTOPJX00LR
- Suitable for IP20 Locations
- SIG qualified Bluetooth Mesh
- Operating Frequency 2.4GHz

## General Specifications

Input Voltage	5V <sub>DC</sub>
Input Current	30mA(Max)
Operation Ambient Temperature Rang	0°C to 60°C (32°F to 140°F)
Operating Relativity Humidity Range	0-90%
Max. Case Temperature per certification	61°C
Sound Rating	A
Service Life	50,000 hours
RFI/EMI	FCC PART 15B CONSUMER
Approvals/Class	cULus Listed, CE, FCC type 15B, RoHS
Location/IP Rating	Suitable for Dry Location/ IP20 (when mounted directly onto luminaire using threaded nut)
Occupancy Detection Angle	62°
Occupancy Detection Area	Max 17m
Daylight Harvesting Type	Ambient Light Sensor
Interface	RJ12 (45 push-in port)
Status Indicators	See Figure1
Operating Frequency	2.4GHz
Modulation	GFSK
The Gain of Antenna	1dBi
RF Output Power	-1dBm
Effective Working Distance	50m line of sight (No obstacle)



Fulham EliteBlue



Fulham's EliteBlue commissioning app can be found on the Apple app store by searching "EliteBlue".  
 For web app, please visit <https://eliteblue.fulham.com>  
 Complete commissioning manual can be found at:  
<https://www.fulham.com/PDFs/eliteBlue-commissioning-manual.pdf>



# ESLTOPJX00LR



## Graphs

Figure 1- Detection pattern

H	X	Y
10' (3.04m)	12' (3.65m)	12' (3.65m)
20' (6.09m)	24' (7.31m)	24' (7.31m)
30' (9.14m)	36' (10.9m)	36' (10.9m)
40' (12.1m)	48' (14.6m)	48' (14.6m)

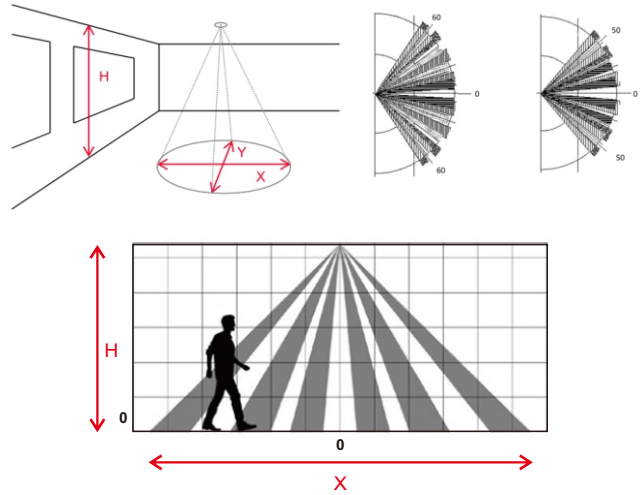

Figure 2 - Detection Area

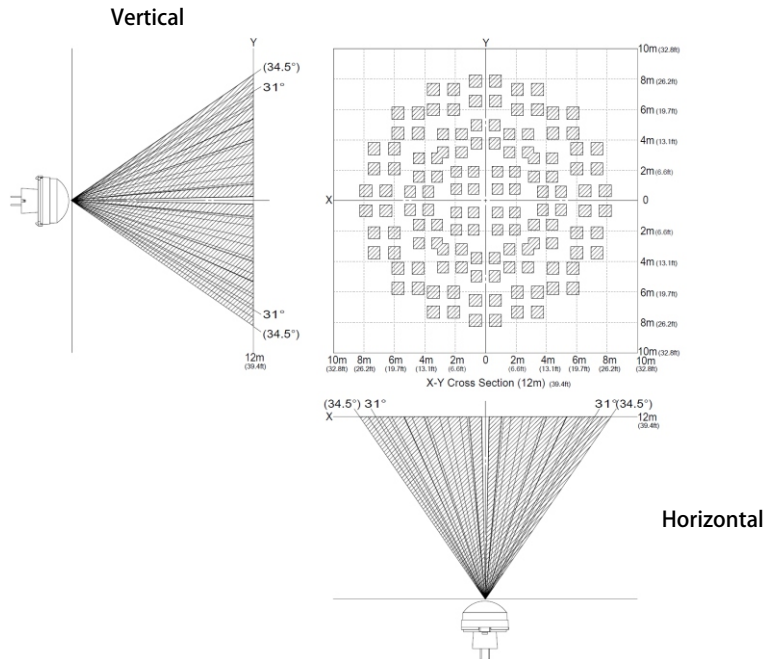
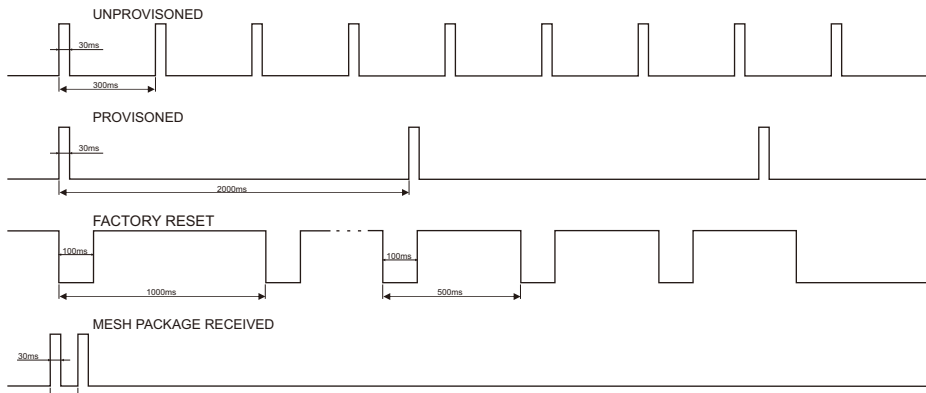

Figure 3- Blinking sequence of Status LED





# ESLTOPJX00LR



## Mechanical Drawings

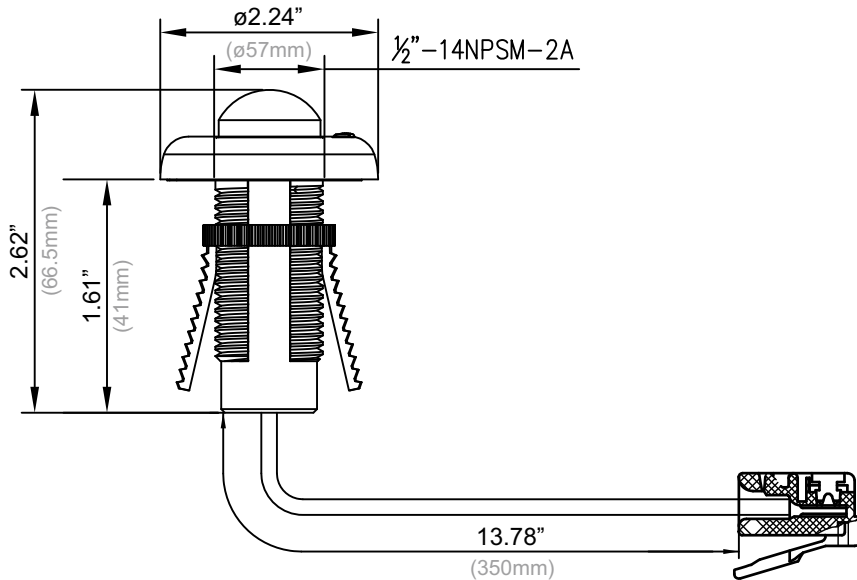

Overall Dimensions	
Diameter	2.24" (57 mm)
Height	2.62" (66.5mm)
Wire Length	
RJ12 Wire (White)	13.78" (350m m)

## Wire Diagram

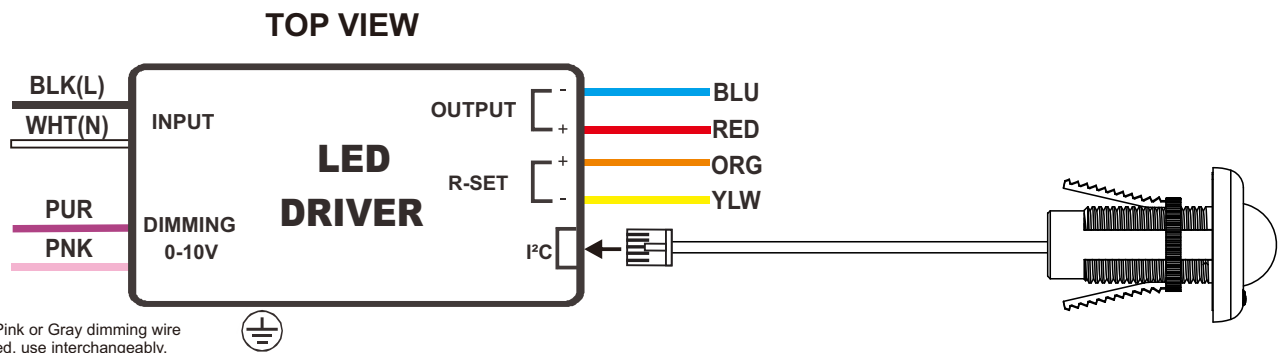

### NOTES :

- 1) This driver must be installed by a licensed electrician
- 2) This driver must be grounded

#### FCC Caution:

This device complies with part 15 of the FCC Rules. Operation is subject to the following two conditions:  
 (1) This device may not cause harmful interference, and (2) this device must accept any interference received, including interference that may cause undesired operation.  
 Any Changes or modifications not expressly approved by the party responsible for compliance could void the user's authority to operate the equipment.



# ESLTOPJX00LR



---

## Guidelines

### Compatible

- Only compatible with Fulham's connected products (EliteControls Workhorse)

---

### Warranty

- Reference Fulham's limited Warranty: <https://cdn.fulham.com/PDFs/Limited-Warranty.pdf>

---

### FCC Caution

- This device complies with part 15 of the FCC Rules. Operation is subject to the following two conditions:  
(1) This device may not cause harmful interference, and (2) this device must accept any interference received, including interference that may cause undesired operation.  
Any changes or modifications not expressly approved by the party responsible for compliance could void the user's authority to operate the equipment.

---

### Notes:

- This equipment has been tested and found to comply with the limits for a Class B digital device, pursuant to part 15 of the FCC Rules:

These limits are designed to provide reasonable protection against harmful interference in a residential installation. This equipment generates uses and can radiate radio frequency energy and, if not installed and used in accordance with the instructions, may cause harmful interference to radio communications. However, there is no guarantee that interference will not occur in a particular installation. If this equipment does cause harmful interference to radio or television reception, which can be determined by turning the equipment off and on, the user is encouraged to try to correct the interference by one or more of the following measures:

- Reorient or relocate the receiving antenna.
  - Increase the separation between the equipment and receiver.
  - Connect the equipment into an outlet on a circuit different from that to which the receiver is connected.
  - Consult the dealer or an experienced radio/TV technician for help.
- FCC RF Radiation Exposure Statement:  
This equipment complies with FCC radiation exposure limits set forth for an uncontrolled environment. This equipment should be installed and operated with a minimum distance of 20cm between the radiator and any part of your body.



# ESLTOPJX00LR



## Accessories

### Switch

Fulham Part Number: **ESRPB-W-EO** (Single)  
**EDRPB-W-EO** (Double)

- Single rocker EnOcean switch
- Double rocker EnOcean switch



### Driver

Fulham Part Number: **T2C1UNV150P-40L** (BLE Compatible Constant Current Programmable Driver)



## Fulham Application Information

Reference Fulham's commissioning guide: <https://www.fulham.com/PDFs/eliteBlue-commissioning-manual.pdf>



Fulham EliteBlue



Fulham's EliteBlue commissioning app can be found on the Apple app store by searching "EliteBlue".  
 For web app, please visit <https://eliteblue.fulham.com>  
 Complete commissioning manual can be found at:  
<https://www.fulham.com/PDFs/eliteBlue-commissioning-manual.pdf>



# ESLTOPJX00LR



## Part Number Matrix

**E** **SL** **T** **OP** **J** **X** **00** **LR**

Lighting Control    Subfamily    Primary Protocol & Powering    Primary Control Channels    Package    Secondary Protocol & Powering    Secondary Control Channels    Detection Range  
 E = EliteControl    SL = Smart Link    T = Bluetooth    OP =Occupancy&Photo sensor    J = J-Box Mount (Conduit Male fitting connector)    X = None    00 =None    LR = Long Range

## Product Image: External PIR Smart Link+



## Packaging

Master Carton

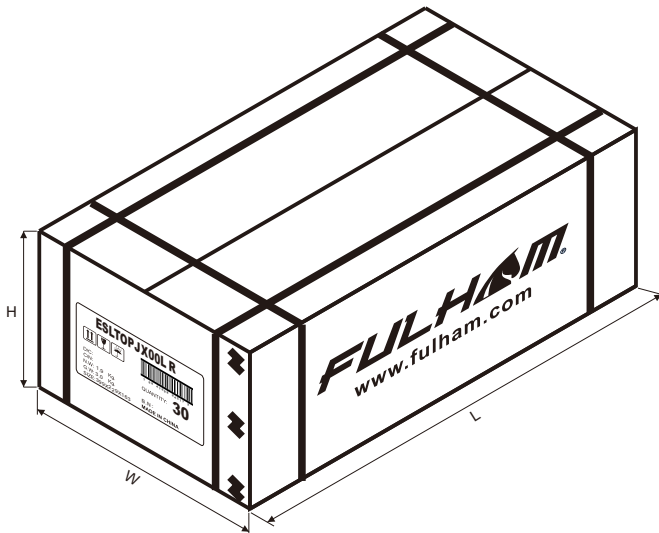

OUTER DIMENSION		
L	W	H
15.71"(399mm)	9.02"(229mm)	6.42"(163mm)
Net Weight	Gross Weight	QUANTITY
0.09 lbs. (0.042 kg)	4.44 lbs. (2.0 kg)	30pcs