



FHSCP-UNV-4W-L



## Important Safety Instructions

When using electrical equipment and this lighting device basic safety precaution should be followed at all times including but not limited to the following:

---

**PLEASE READ CAREFULLY AND FOLLOW ALL INSTRUCTIONS FOR YOUR OWN SAFETY**

**Important: An un-switched AC power source of 120VAC to 277VAC is required.**

**Important: Double insulation used between the supply and battery circuit.**

**Important: Intermittent re-charging circuit.**

**Important: The recharging device remains safe after abnormal operating condition.**

**Caution:** Do not let power supply cords touch hot surfaces.

**Caution:** Do not mount near gas or electric heaters.

**Caution:** Do not use outdoors.

**Caution: Battery is rechargeable LiFePO4 type and must be recycled or disposed of properly.**

Do not use this emergency driver with accessory equipment other than recommended by manufacturer; failure to follow this may cause an unsafe condition. Servicing should only be performed by qualified service personnel.

Do not use this emergency driver for other than intended use.

Equipment should be mounted in locations and at heights where it will not readily be subjected to tampering by unauthorized personnel.

**Important: Indicator (LED light) illuminated indicates battery in charge mode when AC power is applied.**

It is recommended and required by applicable code to test emergency function to ensure proper operation of the system;

LED light source should be illuminated for a minimum of ninety minutes (90).

**ASSEMBLY and FIELD INSTALLATION WIRING: WARNING:** AC power must be off before proceeding with assembly or installation of emergency driver.

**TESTING SYSTEM:** The emergency battery requires a charge minimum of one (1) hour before testing the circuit. A full charge requires twelve (12) hours.

**IMPORTANT:** In order to maintain proper operation and warranty coverage, the battery must be recharged once per year prior to installation.

---



# FHSCP-UNV-4W-L



## Wiring Diagram

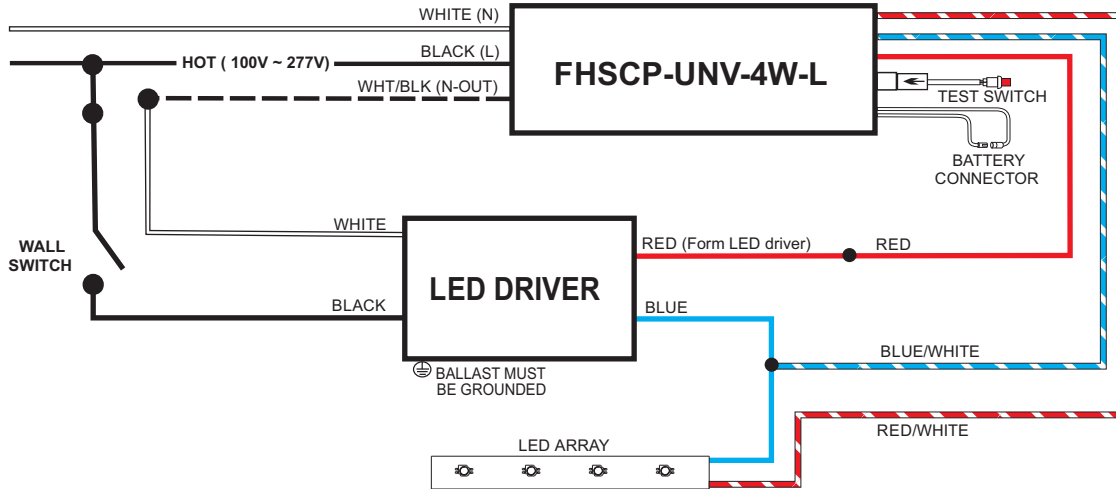

## Wiring Diagram (Emergency Only)

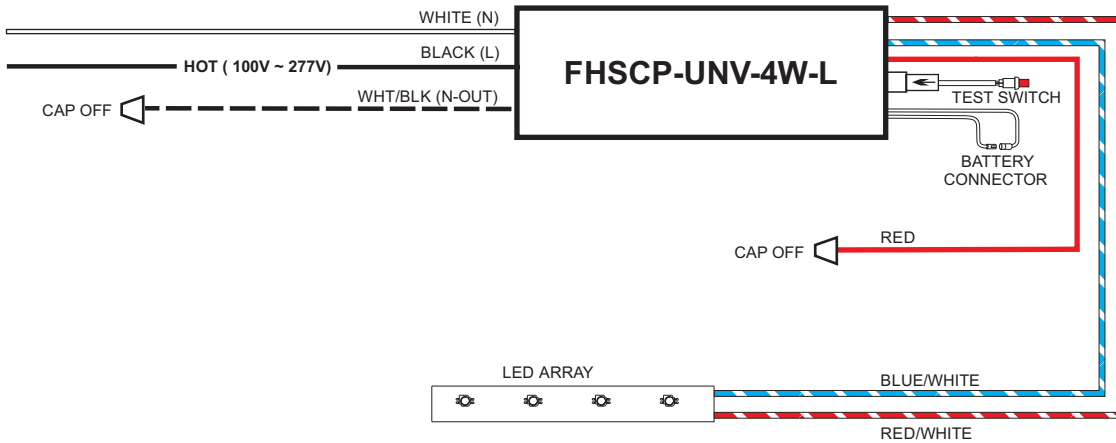

### Input

Wire Color	Length (Inches)
Black	12.01" ±1"
White	12.01" ±1"
Black / White	17.99" ±1"

### Output

Wire Color	Length (Inches)
Red / White	24.02" ±1"
Blue / White	24.02" ±1"
Red	24.02" ±1"
Battery Conn.	12" ±0.02"
Test Switch	28" ±0.02"



# FHSCP-UNV-4W-L



RoHS  
COMPLIANT



## Guideline on calculating emergency illumination level

The purpose of this guideline is to identify the illumination level of the LED luminaire when used with Fulham's FHSCP-UNV-4W-L LED emergency driver. The path of egress illumination level during emergency operation is determined by types of luminaires, Luminaire Efficacy, Luminaire Mounting Height, Emergency Power and some other effects in real application.

Step 1: Select an LED Luminaire, and make sure the LED light source is electrically compatible with Fulham's LED emergency driver. Get the Light Distribution data (usually an .ies file) and Rated Efficacy data (lumen per watt) from luminaire supplier.

If the luminaire is Design Lights Consortium™ (DLC) compliant, you can also get the efficacy information from DLC website.

- Open DLC Qualified Product List (QPL) database search page: <https://www.designlights.org/search/>
- Searching keywords by model, brand name or manufacturer for the luminaire used.
- Find the "Efficacy" data listed on website or calculated by dividing "Light output" by "Wattage", the efficacy value should be shown in lumen per watt (lm/W).

If the luminaire is ENERGY STAR compliant, you can also get the luminaire efficacy information from ENERGY STAR website.

- Open ENERGY STAR certified Light Fixtures database search page: <https://www.energystar.gov/productfinder/product/certified-light-fixtures/results>
- Searching keywords by model, brand name or manufacturer for the luminaire used.
- Find the "Energy Efficiency" data listed on website. If it is showed as "Measured at the Source", please contact with luminaire supplier for additional light loss for this light source inside the fixture. The value should be shown in lumen per watt (lm/W).

Step 2: Determine the Emergency Power and calculate the Emergency Light Output.

FHSCP-UNV-4W-L is programmable output; setting a proper Emergency Power is vital to achieve desired illumination.

Emergency Light Output is equal to the Emergency Power multiply by luminaire efficacy. For example, if the luminaire is 120lm/W and in 3W emergency operation, the total Emergency Light Output is 120lm/W 3W = 360lm.

Step 3: Use industry lighting design software to calculate the illumination level according to the luminaire layout in room, luminaire mounting height, the original .ies file and Emergency Light Output calculated above. If the illumination level cannot meet life safety codes, go back to Step 2 to use a higher Emergency Power or go back to Step 1 to select a higher efficacy luminaire or use more luminaires in the room.

Fulham's FHSCP-UNV-4W-L LED emergency driver is compliant with UL924 standard, according to UL test data, Table 1 and Table 2 below give basic indication to determine the min. Emergency Power and Luminaire Max. Mounting Height for 1 foot-candle illumination based on a single luminaire with typical Lambertian distribution. It is the light designer / construction contractor's responsibility to validate the real illumination level on site, to assure the emergency light illumination level is in accordance with the requirement of Federal, state and local municipal codes. It may differ from the theoretical calculations or simulations on a computer.

Table 1. Min. EM Power for 1fc @10ft vs. Luminaire Efficacy

Luminaire Efficacy (lm/W)	Min. EM Power to achieve 1fc @10ft Mounting Height
80	4W
100	4W
120	4W
140	4W
160	4W
180	4W

Table 2. Max. Mounting Height vs. Luminaire Efficacy

Luminaire Efficacy (lm/W)	Max. Mounting Height for 1fc		
	EM 3W	EM 5W	EM 10W
80	8.1ft	10.1ft	13.9ft
100	8.9ft	11.2ft	15.4ft
120	9.6ft	12.1ft	16.8ft
140	10.3ft	13.0ft	18.1ft
160	10.9ft	13.9ft	19.3ft
180	11.5ft	14.6ft	20.4ft



# FHSCP-UNV-4W-L



## Test Switch Indicator Status:

LED Indicators Status	EM Driver Status/Mode
● Solid Red	Normal working in AC mode.
● Slow Flashing Red, 4s on/1s off	Battery not detected mode.
● Flashing Red, 1s on/1s off	Battery Failure Detected mode.
● Flashing Red, 4s on/4 s off	No Load/LED Load Failure mode.
● Flashing Red, 0.1s on/3s off	Emergency mode.

## Test Switch Operations:

EM Test: Press and hold test button for 1s to enter EM mode for testing in normal AC powered.  
Press and hold test button for 10s to exit emergency mode.