

## INSTALLATION INSTRUCTIONS

VividHorse Universal Voltage (120-277V) DC Engine Retrofit Kit

VKMUNV008RT930A

VKMUNV018RT930A

Reference spec sheet for full part numbers



# LED LIGHT ENGINE APPLICATION PROGRAM

## RETROFIT KIT INSTALLATION MANUAL FOR CEILING MOUNTED LUMINAIRES

### 1.0 INSTALLATION WARNINGS

1. "THIS PRODUCT MUST BE INSTALLED IN ACCORDANCE WITH THE APPLICABLE INSTALLATION CODE BY A PERSON FAMILIAR WITH THE CONSTRUCTION AND OPERATION OF THE PRODUCT AND HAZARDS INVOLVED."
2. "WARNING - Risk of fire or electric shock. LED Retrofit kit installation requires knowledge of luminaires electrical systems. If not qualified, do not attempt installation. Contact a qualified electrician."
3. "WARNING - Risk of fire or electric shock. Install this kit only in the luminaires that has the construction features and dimensions shown in the photographs and/or drawings and where the input rating of the retrofit kit does not exceed the input rating of the luminaire."
4. "WARNING - To prevent wiring damage or abrasion, do not expose wiring to edges of sheet metal or other sharp objects."
5. "WARNING –Risk of fire or electric shock. Luminaire wiring and electrical parts may be damaged when drilling for installation of LED retrofit kit. Check for enclosed wiring and components."
6. "CAUTION – RISK OF FIRE. CONSULT A QUALIFIED ELECTRICIAN TO ENSURE CORRECT BRANCH CIRCUIT CONDUCTOR."
7. THE RETROFIT KIT IS ACCEPTED AS A COMPONENT OF A LUMINAIRE WHERE THE SUITABILITY OF THE COMBINATION SHALL BE DETERMINED BY CSA OR AUTHORITIES HAVING JURISDICTION. PRODUCT MUST BE INSTALLED BY A QUALIFIED ELECTRICIAN IN ACCORDANCE WITH THE APPLICABLE AND APPROPRIATE ELECTRICAL CODES. THE INSTALLATION GUIDE DOES NOT SUPERSEDE LOCAL OR NATIONAL REGULATIONS FOR ELECTRICAL INSTALLATIONS
8. Only those open holes indicated in the photographs and/or drawings may be made or altered as a result of kit installation. Do not leave any other open holes in an enclosure of wiring or electrical components.

### 1.0 AVERTISSEMENTS D'INSTALLATION

1. CE PRODUIT DOIT ÊTRE INSTALLÉ SELON LE CODE D'INSTALLATION PERTINENT, PAR UNE PERSONNE QUI CONNAÎT BIEN LE PRODUIT ET SON FONCTIONNEMENT AINSI QUE LES RISQUES INHÉRENTS.
2. AVERTISSEMENT - Risque d'incendie ou de choc électrique. L'installation de ce nécessaire de modernisation exige une personne familière avec la construction et le fonctionnement du système électrique du luminaire et des risques associés. Toute personne qui n'est pas qualifiée ne doit faire aucune tentative d'installation et doit contacter une personne qualifiée.
3. AVERTISSEMENT - Risque d'incendie ou de choc électrique. N'installer ce nécessaire que dans les luminaires ayant les caractéristiques de construction et les dimensions sont conforme à celles illustrées dans les photos et/ou les dessins, La puissance nominale d'entrée du kit de mise à niveau ne dépasse pas la valeur nominale d'entrée du luminaire.
4. AVERTISSEMENT - Afin de prévenir l'endommagement ou l'abrasion des câbles, éviter tout contact entre ces derniers et le bord d'un objet tranchant tel qu'une tôle.
5. "AVERTISSEMENT -Risk d'incendie ou de choc électrique. Le câblage du luminaire et les pièces électriques peuvent être endommagés lors du forage pour l'installation d'un kit de reconditionnement LED. Vérifiez le câblage et les composants inclus. "
6. ATTENTION – RISQUE D'INCENDIE, CONSULTER UN ÉLECTRICIEN QUALIFIÉ POUR VOUS ASSURER QUE LES CONDUCTEURS DE LA DÉRIVATION SONT ADÉQUATS.
7. LE KIT DE RÉNOVATION EST ACCEPTÉ COMME COMPOSANT D'UN LUMINAIRE LORSQUE L'ADAPTATION DU LA COMBINAISON EST DÉTERMINÉE PAR CSA OU LES AUTORITÉS AYANT JURISDICTION. PRODUIT DOIT ÊTRE INSTALLÉ PAR UN ÉLECTRICIEN QUALIFIÉ CONFORMÉMENT AUX NORMES APPLICABLES ET CODES ÉLECTRIQUES APPROPRIÉS. LE GUIDE D'INSTALLATION NE REMPLACE PAS LOCAL OU REGLEMENTATION NATIONALE DES INSTALLATIONS ELECTRIQUES
8. Seuls les trous ouverts indiqués sur les photographies et/ou les dessins peuvent être réalisés ou modifiés à la suite du kit installation. Ne laissez aucun autre trou ouvert dans un boîtier de câblage ou de composants électriques.

### 2.0 CCT SELECTION INDICATION

1. The VividHorse DC Engine Retrofit Kit is a dual-channel LED product, that allows for CCT selection via the dip switch on the PCB. Available CCTs include 2700K, 3000K, 3500K, 4000K, 4500K and 5000K.
2. A pre-set CCT will come from the factory. Check the product label or packaging to see the pre-set CCT level.
3. Change the dip switch position to “ON” (1~6) to set the desired CCT level.

**NOTE: ONLY keep one dip switch in the “ON” position, not doing so may result in an undesired CCT.**

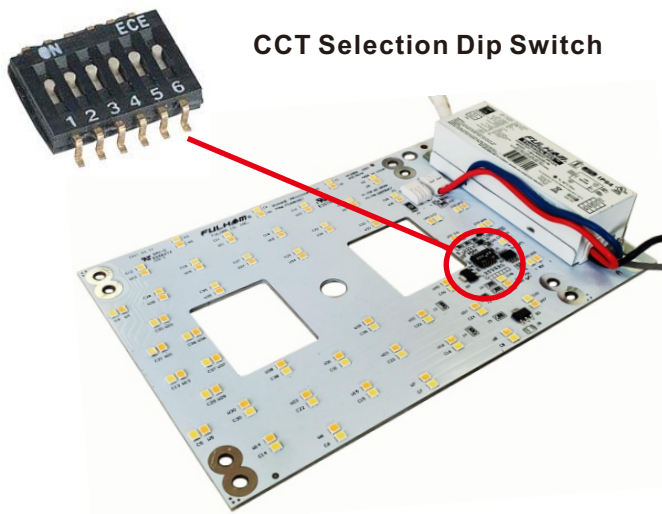

**CCT Selection Dip Switch**

**CCT Indication Table**

	1	2	3	4	5	6
<b>2700K</b>	<b>ON</b>	OFF	OFF	OFF	OFF	OFF
<b>3000K</b>	OFF	<b>ON</b>	OFF	OFF	OFF	OFF
<b>3500K</b>	OFF	OFF	<b>ON</b>	OFF	OFF	OFF
<b>4000K</b>	OFF	OFF	OFF	<b>ON</b>	OFF	OFF
<b>4500K</b>	OFF	OFF	OFF	OFF	<b>ON</b>	OFF
<b>5000K</b>	OFF	OFF	OFF	OFF	OFF	<b>ON</b>

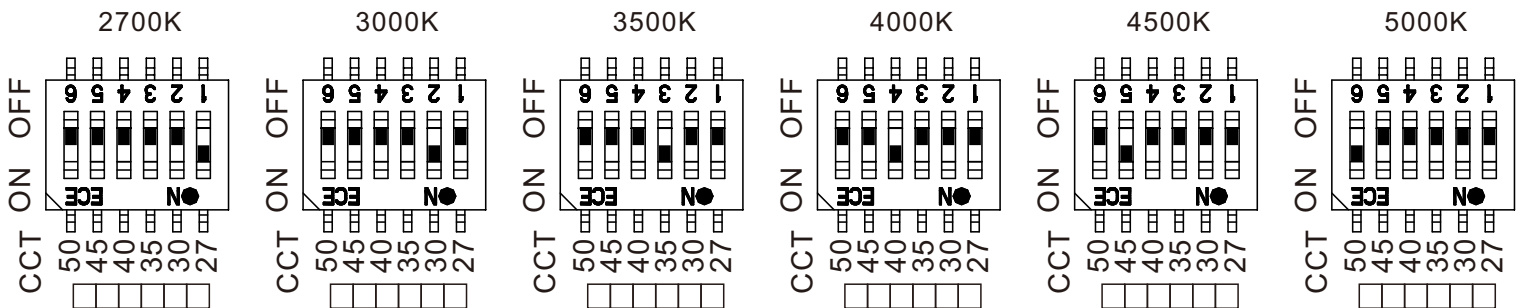

#### Retrofit Kit Warning Label

This luminaire has been modified and can no longer operate the originally intended lamp.  
**REPLACE ONLY WITH FULHAM ELECTRONIC CO. : VKMUNV0\*\*RT930A**  
 Ce luminaire a été modifié et ne peut plus utiliser la lampe prévue à l'origine.  
**REPLACER UNIQUEMENT AVEC FULHAM ELECTRONIC CO. : VKMUNV0\*\*RT930A**

### 3.0 ORIGINAL LUMINAIRE DIMENSIONS

#### Original Luminaire

Mfr: Indessa Lighting - Model: 562 Series

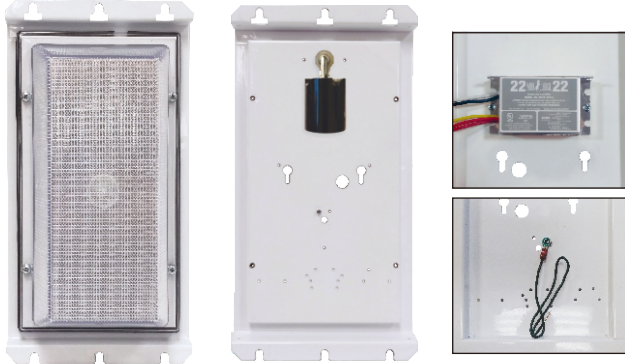

#### Minimum Luminaire Dimensions

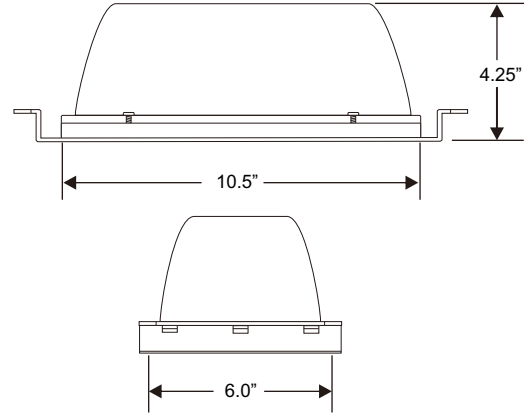

- Remove all the original luminaire parts, hardware, lamp, ballast, and socket in order to begin the retrofit.
- Original luminaire diffuser and original ground wire will need to be kept for this retrofit.
- This DC Engine Kit can be retrofitted into any surface wall or ceiling luminaire with a similar shape and diameter/height greater or equal to the minimum dimensions described above, or volume greater or equal to 158.66 cubic inches.

### 4.0 RETROFIT KIT COMPONENTS

Retrofit kit components will be provided as listed below:

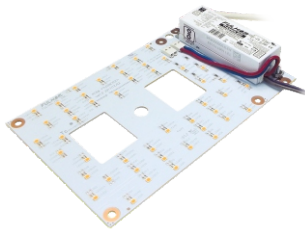

UNV DC Engine



Mounting Hardware



Input Power Connector

This luminaire has been modified and can no longer operate the originally intended lamp.  
**REPLACE ONLY WITH FULHAM ELECTRONIC CO. : VKMUNV0\*\*RT330A**  
 Ce luminaire a été modifié et ne peut plus utiliser la lampe prévue à l'origine.  
**REPLACER UNIQUEMENT AVEC FULHAM ELECTRONIC CO. : VKMUNV0\*\*RT330A**

Retrofit Warning Label

### 5.0 RECOMMENDED TOOLS (Not Included)

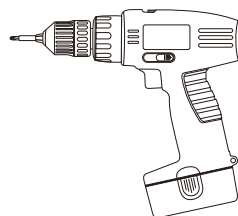

Power Drill W/ Philips Bit

### 6.0 RETROFIT KIT DESCRIPTION

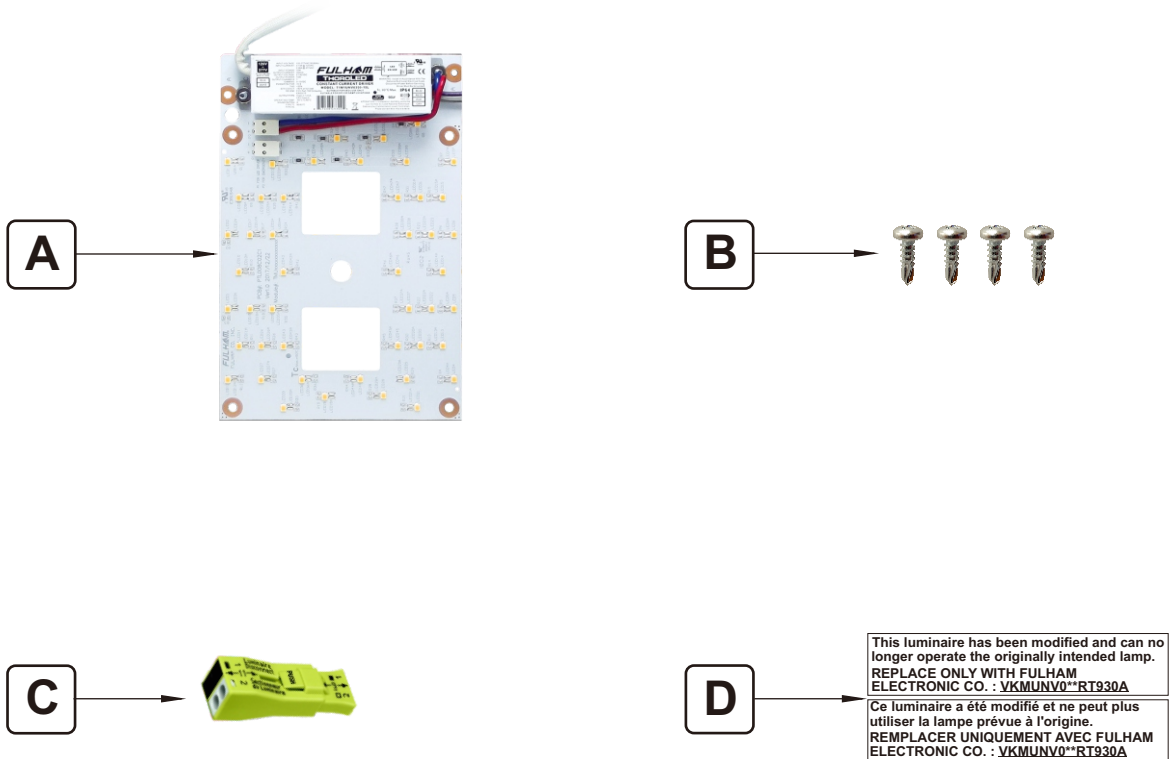

ITEM	DESCRIPTION	QTY
<b>A.</b>	DC Engine	1
<b>B.</b>	6-20 X 3/8" Pan Head Self Drilling Screws	4
<b>C.</b>	Input Connector	1
<b>D.</b>	Retrofit Labels	2

### 7.0 RETROFIT KIT ASSEMBLY

1. Start by removing the original lamp, ballast and socket from the luminaire. See Figure 1.  
**NOTE: The original luminaire ground wire will need to be kept for this retrofit.**
2. Pass the DC Engine (A) input power wires and dimming wires (if available) through the luminaire wire hole. See Figure 2.
3. Place the DC Engine (A) onto the luminaire back plate as shown in Figure 3.  
**NOTE: LED Engine must make direct contact with the back plate when installed in order to provide sufficient heat sinking to properly manage thermals for safety and warranty purposes.**
4. Use the supplied self-drilling screws (B) to attach the DC Engine (A) to the luminaire housing. See Figure 4.
5. Place the provided labels in the outer space of the luminaire after the DC Engine installation has been completed. Labels must be clearly visible and should not be obscured by line voltage cables. See Figure 5.
6. Completed assembly should look like Figure 5.
7. Luminaire is now ready to be installed. Please see below for instructions on connecting line voltage to the luminaire.

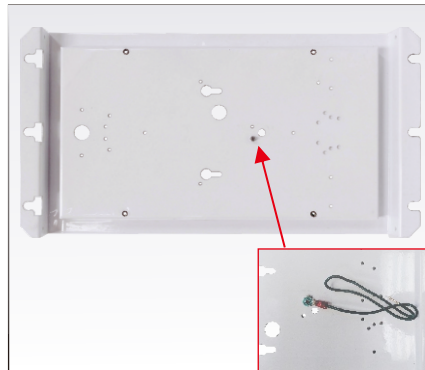

Figure 1

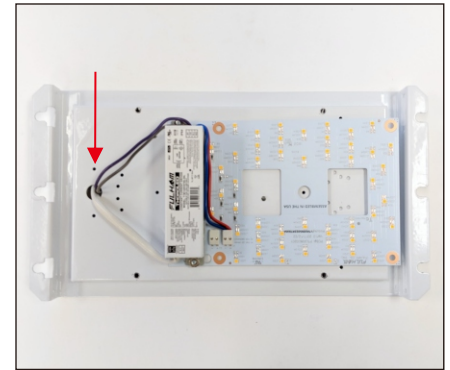

Figure 2

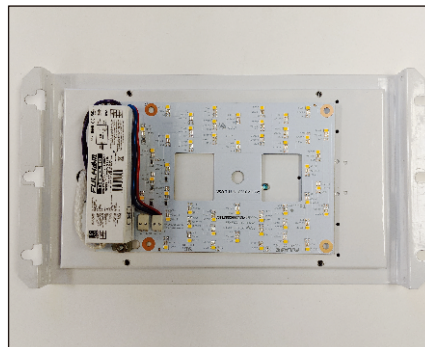

Figure 3

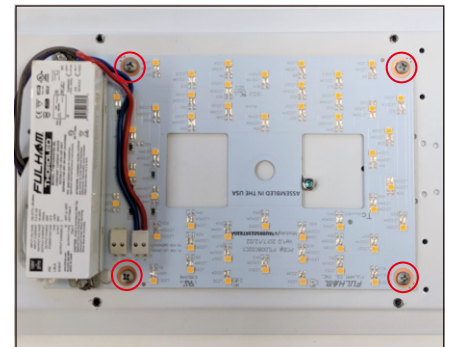

Figure 4

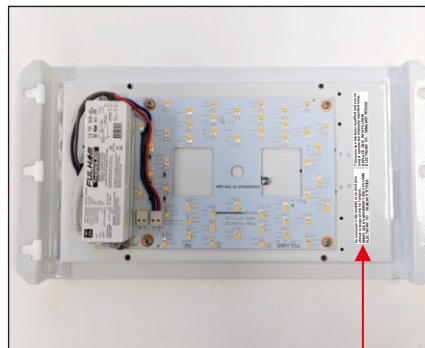

Figure 5



Figure 6

Re-attach and secure the lens once installation is completed, retrofit should look like Figure 6.

This luminaire has been modified and can no longer operate the originally intended lamp. REPLACE ONLY WITH FULHAM ELECTRONIC CO. VKMLINVR-RT330A  
Ce luminaire a été modifié et ne peut plus utiliser la lampe prévue à l'origine. REMPLACER UNIQUEMENT AVEC FULHAM ELECTRONIC CO. VKMLINVR-RT330A

### Connecting Power to the DC Engine:

- 1) Connect the green wire (Ground) from the luminaire to the Ground that is being fed by the power source. Connect these two wires by using a wire connector with a minimum 18AWG rating.
- 2) Connect the white wire (Neutral) from the LED Engine to the Neutral being fed by the power source. Connect these two wires by using a wire connector with a minimum 18AWG rating.
- 3) Connect the Black wire (Line) from LED Engine to the Line being fed by the power source. Connect these two wires by using a wire connector with a minimum 18AWG rating.

### 8.0 WARRANTY

- Please refer to LED Engine kit spec sheet for warranty information