



TJTUNV015AR9xxB



DirectAC UNV Retrofit Kit Engines

- Integrated AC Direct Drive (No DC Driver)
- Universal Voltage (120~277) AC Engine
- Suitable for open or fully enclosed luminaires
- Suitable for luminaires with plastic and glass lenses
- All 90CRI product meets CEC Title 24 requirement
- cULus Classified 1598C
- cULus Recognized 8750
- Energy Star Luminaire 2.1 Listed (for rebate programs) [Ⓞ]
- Energy Star Luminaire CSD [Ⓞ]

General Specifications

Input Voltage / Frequency [Ⓞ]	120~277VAC (+/- 10%) / 50-60Hertz
Input Current [Ⓞ]	~0.125A @120V ~0.066A @230V ~0.055A @277V
Input Power [Ⓞ]	15W (+/- 1W)
Input PF	>0.98
THD	<20%
Operating Frequency per Energy Star @120V/60Hz	120Hz
Max Lumen Output @ Full Power [Ⓞ]	1466 lumens @ 4000K / 90 CRI
Dimming Type/Range @120V ONLY	Leading Edge (TRIAC) or Trailing Edge (ELV) /100% ~ 10%
Beam Angle	120°
CRI / CCT	90 / 2700K, 3000K, 3500K, 4000K; 5000K is made to order (MTO)
Operating Temperature Range (ta)	-35 to 50°C / -31°F to 122°F
Maximum Engine Case Temperature (Tc)	L70: Tc max=85°C (185°F) / L90: Tc max=85°C (185°F)
Maximum Lens Temperature	Lens: 90°C (194°F)
Estimated Lumen Maintenance (at Max Tc)	L70= >54,000 hours / L90= 35,000 hours
Color Consistency	Binning per ANSI C78.377-2015 @85°C; 3 SDCM
Overall Size	7.4" L x 4" W x 0.71" H (187.96mm L x 101.6mm W x 18.03MM H)
Wire Type/ Length	18AWG / 12" Black and White wires
LED Quantity	48 Pcs.
Weight	130g / 0.28lbs.
Packaging: Carton / Master Carton	24pcs / 96pcs
Maximum Screw Installation Torque	60in-lb (960in-ozf)
Safety/Compliance	DirectAC Engines: cURus (File # E486778) TATUNV015ARxxxA DirectAC Retrofit Kits: cULus (File # E486779) TJTUNV015ARxxxB RoHS Compliant Dry and Damp Location IC Over Temperature Control Energy Star Luminaire 2.1 Listed [Ⓞ] Energy Star Luminaire CSD [Ⓞ] CEC JA8-2016
RFI/EMI	FCC Part 15B Consumer, EN55015
Input Surge Test	2.5kV Common and Differential mode (Per ES Ring Wave Test)
Sound Rating / Noise	A / <24 dBA
Percent Flicker / Flicker Index	<25% / <0.0527
Protective Lens / Enclosure	High Voltage Barrier / 2.5mm Clear Polycarbonate 5VA Flame rated
Lens Transmittance	>92%
PCB Material	MCPCB
Warranty	5 years @ 85°C (185°F) Tc from the date of manufacture
Electrolytic Capacitor Rating	>60,000 hours

[Ⓞ] See page #4 "Certification Chart" for exact models.
[Ⓞ] Measured electrical data per UL file



TJTUNV015AR9xxB

JA8-2016



Electrical and Optical Specifications

Color Temperature	DirectAC Engine Part Number	Input Power	Nominal Luminous Flux @ 90 CRI	Engine Efficacy @ 90 CRI
2700K	TJTUNV015AR927B	15W	1346 lumens	90 lm/W
3000K	TJTUNV015AR930B	15W	1397 lumens	93 lm/W
3500K	TJTUNV015AR935B	15W	1415 lumens	94 lm/W
4000K	TJTUNV015AR940B	15W	1466 lumens	98 lm/W
5000K	TJTUNV015AR950B	15W	1501 lumens	100 lm/W

NOTES:

- 1) Nominal luminous flux includes a 7.5% loss due to lens. Use a 1.075 multiplier when lens is removed.
- 2) Electrical and optical specifications are based on Tc mod = 25°C @120V. Reference Amb. Temp. vs Rel. Lum. Flux for other temperatures.
- 3) Specifications are subject to change without notice.
- 4) Meets CEC Title 24 requirement.
- 5) ~10% lumen depreciation @277V input.



Thermal Specifications

③ DirectAC Engine Retrofit Kit (B)

Storage Temperature Range	-40°C (-40°F) to 80°C (176°F)
Operating Ambient Temperature Range (ta)	-35°C (-31°F) to 50°C (122°F)
Maximum Engine Case Temperature (Tc)	L70: Tc max=85°C (185°F) / L90: Tc max=85°C (185°F)
Maximum Lens Temperature	90°C (194°F)

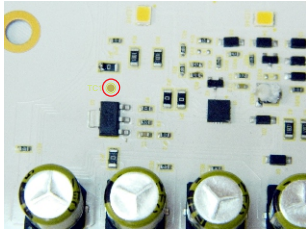

Tc located on module

Thermal De-Rating: Tc vs. Luminous Flux

Module Case Temperature (Tc)	Luminous Flux Multiplier
25°C	1.000
30°C	0.988
35°C	0.975
40°C	0.963
45°C	0.951
50°C	0.938
55°C	0.926
60°C	0.914
65°C	0.901
70°C	0.889
75°C	0.877
80°C	0.864
85°C	0.852
90°C	0.840
95°C	0.827
100°C	0.815

NOTES:

- 1) Refer to LED Engine Retrofit Kit Installation Instructions for further detail.
- 2) This LED Engine Kit can retrofit any luminaire with a dimension/volume greater or equal to the minimum dimensions shown below and on the Installation Instructions.
- 3) This LED Engine Kit can be used with luminaires similar to the one illustrated on the Installation Instructions.

③ Suitable for surface mounted luminaire with minimum dimensions or volume: 10.5" L x 4.25" W x 6" H or 158.66 cubic inches



TJTUNV015AR9xxB

JA8-2016



Certification Chart

Energy Star™ TM-21 Calculator Data

Model	TJTUNV015AR9xxB
Classification	
	YES
	YES
	YES
	YES
	YES

Tc Module	Reported L70	Reported L90
50°C	>54,000 Hrs	>54,000 Hrs
100°C	>54,000 Hrs	35,000 Hrs
110°C	>54,000 Hrs	30,000 Hrs
Tc Module	Calculated L70	Calculated L90
50°C	180,000 Hrs	55,000 Hrs
100°C	116,000 Hrs	35,000 Hrs
110°C	99,000 Hrs	30,000 Hrs

NOTES:

- 1) Energy Star CSD:
https://www.energystar.gov/products/lighting_fans/certified_lighting_subcomponent_database_csd
- 2) Energy Star Listed:
https://www.energystar.gov/productfinder/product/certified-light-fixtures/results?scrollTo=342&search_text=fulham&fixture_type_isopen=&markets_filter=United+States&zip_code_filter=&product_types=Select+a+Product+Category&sort_by=light_output_lumens&sort_direction=asc&page_number=0&lastpage=0



TJTUNV015AR9xxB

JA8-2016



Compatible Tested Dimmers

(Contact Fulham for other alternatives)

(TRIAC or ELV Dimmers)

Manufacture	Model	Type
Core	SI061BR-PTA	TRIAC (Leading Edge) Incandescent Analog
Legrand	RH703PTC	TRIAC (Leading Edge) Incandescent Analog
Leviton	002-6633-PLW	TRIAC (Leading Edge) Incandescent Analog
Leviton	DDE06-BLZ	ELV (Trailing Edge)
Leviton	R70-6631-1LW	TRIAC (Leading Edge) Incandescent Analog
Leviton	RDL06-10Z	TRIAC (Leading Edge)
Lutron	CT-600P	TRIAC (Leading Edge)
Lutron	DV-600P	TRIAC (Leading Edge)
Lutron	LG-600P	TRIAC (Leading Edge)
Lutron	D-600R	TRIAC (Leading Edge) Incandescent Analog
Lutron	SELV-303P	ELV (Trailing Edge)
Lutron	S-600	TRIAC (Leading Edge)
Lutron	S-603P	TRIAC (Leading Edge) Incandescent Analog



TJTUNV015AR9xxB

JA8-2016



DirectAC Engine Equivalency Chart

DirectAC Engine/Kit (15W)				CFL					
Engine/Kit Part Number	System Wattage	Lumen Output	Efficacy	CFL Style	Lamp Wattage	# of Lamps	Total Wattage	Lumen Output	Efficacy
TJTUNV015AR9xxB	15W	1466 lm (4K/90CRI)	98 lm/W	Quad	13W	2	26W	1550 lm	59 lm/W
					18W	1	18W	1075 lm	
					26W	1	26W	1550 lm	
				Triple	13W	2	26W	1650 lm	63 lm/W
					18W	1	18W	1020 lm	56 lm/W
					26W	1	26W	1536 lm	59 lm/W
				Circline T9	22W	1	22W	775 lm	35 lm/W
				Circline T5	22W	1	22W	1530 lm	69 lm/W

NOTES:

- 1) For reference only, several factors apply.
- 2) Emergency systems are not UL classified for field installation.



TJTUNV015AR9xxB

JA8-2016



Flicker Test Data Summary

(Test performed by third party lab using, Lutron S-600P dimmer)

With Dimmer at 100%

100% Light Output Percent Amplitude Modulation					
No Filter	40 Hz	90 Hz	200 Hz	400 Hz	1000 Hz
21.04%	0.71%	2.00%	17.56%	18.24%	19.87%
Measurement Period:		2.000 sec		Noise: 18.6 dBA	
Recording Interval:		4.00E-05 sec		Fraction of rated light output: 100%	
Flicker Index:		0.0527			

With Dimmer at 20%

20% Light Output Percent Amplitude Modulation					
No Filter	40 Hz	90 Hz	200 Hz	400 Hz	1000 Hz
19.45%	1.04%	2.27%	12.86%	15.80%	17.08%
Measurement Period:		2.000 sec		Noise: 18.3 dBA	
Recording Interval:		4.00E-05 sec		Fraction of rated light output: 21%	
Flicker Index:		0.0406			

With Dimmer at Minimum Light Output

Minimum Light Output Percent Amplitude Modulation					
No Filter	40 Hz	90 Hz	200 Hz	400 Hz	1000 Hz
25.00%	0.73%	1.30%	9.00%	11.42%	12.26%
Measurement Period:		2.000 sec		Noise: 18.3 dBA	
Recording Interval:		4.00E-05 sec		Fraction of rated light output: 10%	
Flicker Index:		0.0289			



TJTUNV015AR9xxB

JA8-2016



Battery Backup Option

- FHSCP-UNV-6W-L-SD: Emergency LED Driver for Direct AC Engines



Mechanical Drawing

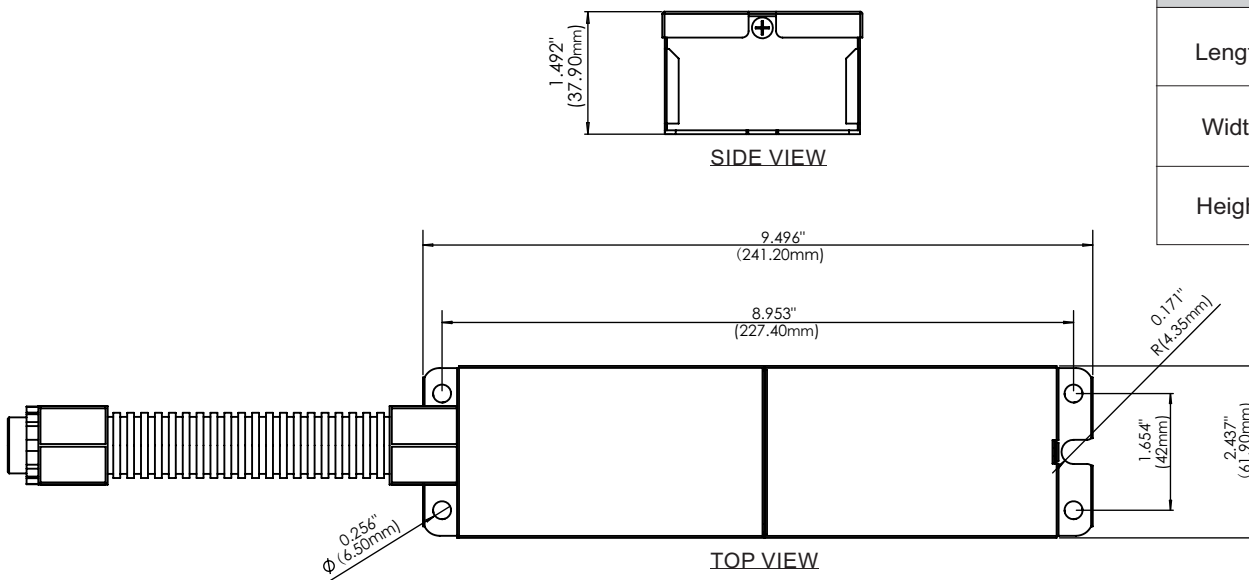

Overall Dimensions	
Length	9.49" (241.2mm)
Width	2.43" (61.9mm)
Height	1.49" (37.9mm)

Wiring Diagram

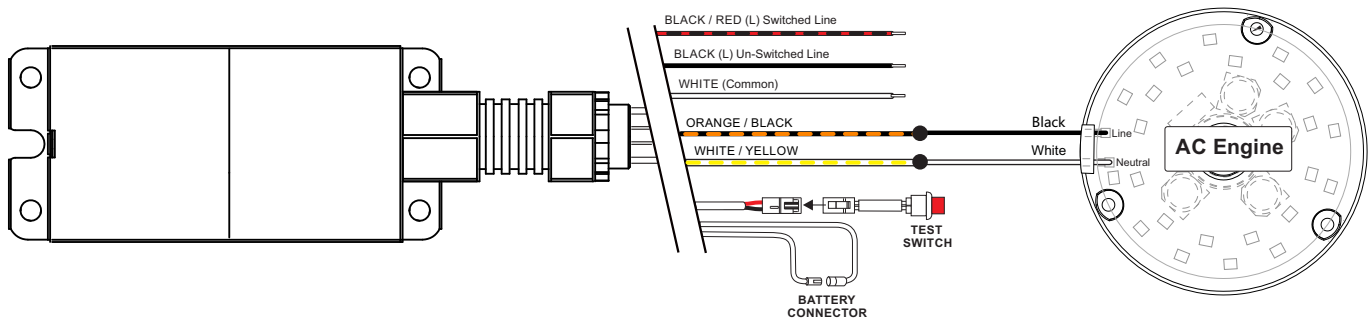

Specification Sheet:

- <https://www.fulham.com/PDFs/SpecSheets/FHSCP-UNV-6W-L-SD-2020-857-spec.pdf>



TJTUNV015AR9xxB

JA8-2016



Mechanical Drawings

(Scale 13 : 20)

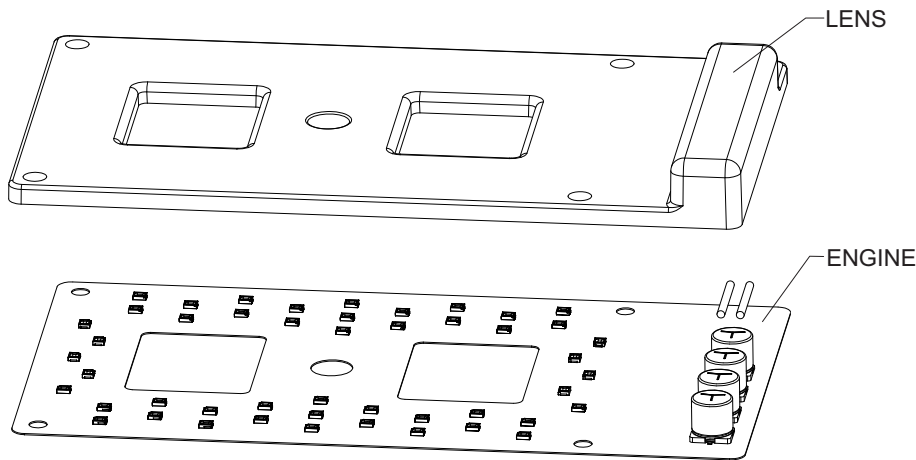

Overall Dimensions	
Length	7.4" [187.96mm]
Height	0.71" [18.03mm]
Width	4" [101.6mm]
Wire Length AC Input (Black / White)	12" [304.8mm]

Exploded View

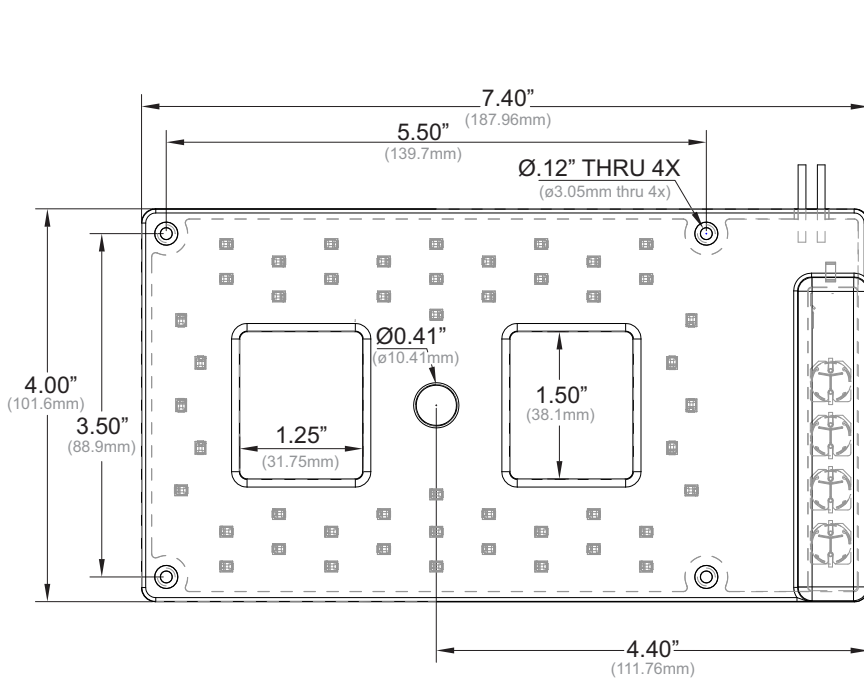

Top View

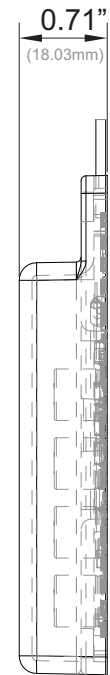

Side View



TJTUNV015AR9xxB

JA8-2016



RoHS COMPLIANT

Color and Binning

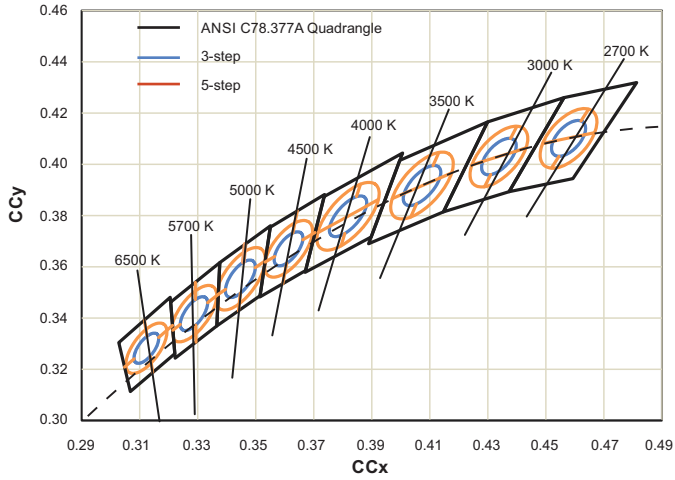

Optical Spectrum

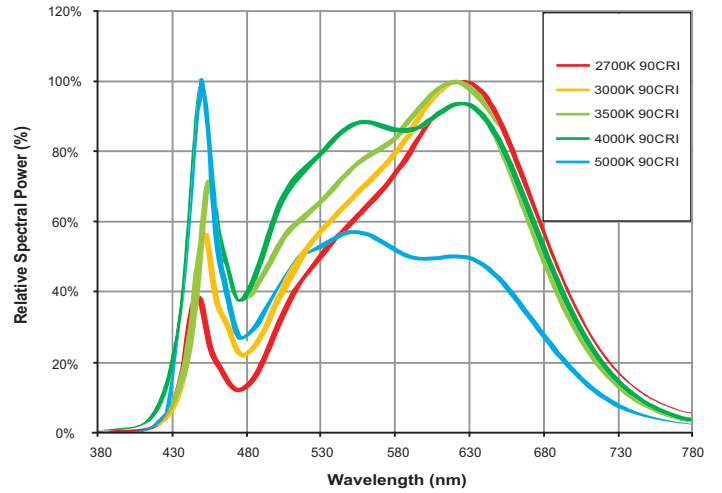

NOTES:

- 1) The Color and Binning and Optical Spectrum charts are for reference only. For more detailed info, contact factory.
- 2) Binning per ANSI C78.377-2015 @ 85°C; 3 SDCM.
- 3) The Optical Spectrum values vary depending on product type and color rank.



Guidelines

Reduced Flicker Operation Feature

- DirectAC Engine models have added circuitry to help reduce the Flicker when operated on the 50/60Hz power lines. The Flicker percentage on these models is below 30% when operated at line voltage, per CEC requirement. Dimming by line voltage devices may increase the Flicker percentage as the power levels are reduced.

Hi-Pot Testing (Caution)

- All DirectAC Engine models are Hi-Pot tested on the Fulham production line. We advise NOT to apply AC high voltage Dielectric test to LED products as this may damage the sensitive electronic components as well as the LEDs. Please inspect the connection wires for any nicks or cuts in the insulation during and after installation.

Termination Notes

- A luminaire disconnect UL listed connector is included, as part of Fulham's retrofit kit only, to meet Energy Star requirements.
- Use solid wire size 18AWG/12" per pole, rated at max 600V load and 105°C operating temperature.
- Strip wires to 11-13mm (0.47in.).
- Connector not for multiple use.

For additional information on Wago's 873 Series Lumi-Nuts® and IDEAL's 102X connector, please visit:

http://www.wago.com/infomaterial/wago_ebook/51261593/flipviewerxpress.html

<https://idealind.com/shop/30-102x.html>



Daisy Chain

Environmental Rating

- DirectAC Engines are rated for dry and damp locations.

IC Over Temperature Control

- DirectAC Engine models have built in Thermal management, if the unit experiences higher than normal ambient temperatures the circuit by design will reduce the drive current to the LED there by reducing the thermal impact on the LED's.

Fastening to Luminaire

- When installing this LED Engine use screws with a diameter less than 0.13in. [3.4mm]. The LED Engine must be mounted on a flat surface and all mounting holes must be used to ensure good contact between the back side of the LED Engine and the mounting surface. Refer to max specified torque for installation. Suggested screw sizes: #5 or M3 Pan Head screw. Fulham provides four 6-20 X 5/8" Flat Head Self Drilling Screws, see instruction sheets for further details
- During installation process do not remove plastic film backing.

Electrostatic Sensitive Product (ESD)

- Fulham LED products should be handled with proper measures to protect against any potential ESD damage.
- When servicing, personnel should be ground and direct contact with LED should be avoided.

Thermal Management

- Proper thermal management should be employed to ensure life and reliability of product.

Wiring

- Intended for 120~277V application ONLY.
- Connect the Black wire from the DirectAC Engine to the building/source Line by using the proper connectors or wire nuts.
- Connect the White wire from the DirectAC Engine to the building/source Neutral by using the proper connectors or wire nuts.
- DirectAC Engine does not need grounding, but the luminaire must be grounded.
- Intended to be wired on dedicated lighting branch circuit.
- Do not wire on same branch circuit as motors, inductive type loads or heavy machinery which may introduce spikes, noise and other abnormalities onto the Line. Doing so may result in damage to the unit or abnormal lighting conditions.



TJTUNV015AR9xxB

JA8-2016



RoHS COMPLIANT

Part Number Matrix

T J T UNV 015 AR 9 40 B

Engine Type ⓐ J = DirectAC Engine Retrofit Kit (Classified)	Dimming T = TRIAC/ELV @120V Only	Input Voltage UNV = 120V~277V	Input Power 015 = 15W	Material & Shape AR = MCPCB+wire Rectangular	ⓐ 9 = 90 CRI	Color Temperature ⓐ 27 = 2700K ⓐ 30 = 3000K ⓐ 35 = 3500K ⓐ 40 = 4000K 50 = 5000K	ⓐ B = DirectAC Engine+Lens (Retrofit Kit)
-------------------------------------------------------------------	-------------------------------------	----------------------------------	--------------------------	-------------------------------------------------	--------------	-------------------------------------------------------------------------------------------------	-------------------------------------------

NOTES:

- 1) DirectAC Engines standard model "B" comes with engine and lens.
- 2) Specifications are subject to change without notice.
- 3) All 90CRI product meets CEC Title 24 requirement.
- ⓐ Standard Product offering. (90CRI / 5000K option is made to order with MOQ and lead time.)
- ⓐ LED Engine Retrofit Kit includes mounting hardware, retrofit labels, and installation instructions.

Product Image: 15W DirectAC UNV Rectangular Engine Kit

TJTUNV015AR9xxB

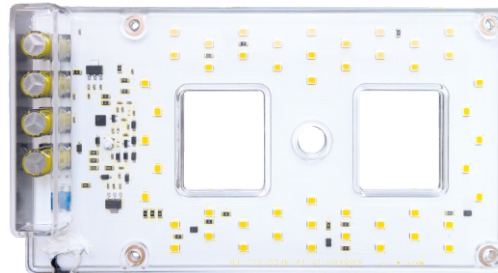

Installation Instructions

Avvertimento: Rischio d'incendio et d'électrocution, câblage des luminaires et pièces électriques peuvent être endommagés lors du forage pour l'installation du kit de conversion à DEL. Vérifier le câblage et les composants ci-joint.

WARNING: Risk of fire and electrical shock. Luminaire wiring and electrical parts may be damaged when drilling for installation of LED retrofit kit. Check for enclosed wiring and components.

WARNING: Cancer and Reproductive Harm www.P65Warnings.ca.gov



DirectAC UNV Retrofit Kit Engines:
Hardware, Quick disconnect, Labels & Installation Instructions

Packaging

Carton

Master Carton

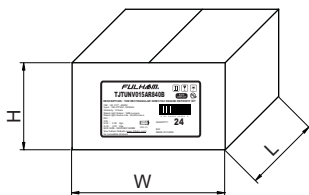

OUTER DIMENSION		
L	W	H
15.55"(395mm)	12.99"(330mm)	6.30"(160mm)
Net Weight	Gross Weight	QUANTITY
7.28 lbs. (3.30kg)	8.16 lbs. (3.70kg)	24pc.

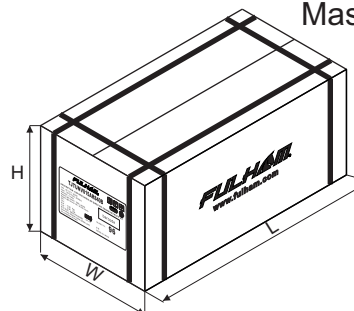

OUTER DIMENSION		
L	W	H
26.77"(680mm)	16.33"(415mm)	13.78"(350mm)
Net Weight	Gross Weight	QUANTITY
29.10 lbs. (13.20kg)	34.83 lbs. (15.80kg)	96pcs.

Twenty-Four (24) LED AC Engine retrofit kits inside each carton.

Four (4) cartons inside each Master Carton.