

Features

- Support DALI-2+PUSH dimming mode
- 10-level current output can be realized by DIP-switch
- Soft dimming and flicker-free at any brightness
- Dimming range 1~100%, output current accuracy 1%
- Standby power input<0.5W, meets the requirements of ErP certification
- High PF, high efficiency, low THD
- Screw-free and pressing type strain relief, supports thicker cables and is easier to install
- Independent input and output strain relief, stronger wiring
- Intelligent LED hot-plug protection function
- SELV and Class II design, suitable for use inside of the light
- Passed CE, DALI-2 and other certifications
- IP20 protection grade, indoor use
- Nominal life-time up to 100,000 h

Interfaces

- DALI-2(DALI-2 DT6)
- PUSH(PUSH-DIM)

Functions

- Support central emergency application (dimming normal in DC input)
- Support self-contained emergency application
- Protective features (short-circuit, overload, no-load, hot plug-in protection)

Suitable for lights

- Suitable for lights with independent drivers such as downlights, spotlights, panel lights, etc
- Not suitable for lights with built-in drivers

Typical applications

- LED indoor lighting
- LED office lighting
- LED commercial lighting





T1A1240035S-10FE

SPECIFICATIONS



- DALI-2 Dimmable Constant current LED Driver
- Support DALI dimming 1 to 100%
- Support PUSH dimming function
- Output Wattage : 10.5W Max
- Output voltage range of 6-42Vdc
- Output Current: 100 - 350mA
- Flicker-free at any brightness, meeting the standard of flicker-free(IEEE 1789-2015)
- Application
 - LED indoor lighting
 - LED office lighting
 - LED architectural lighting
 - LED panel lamp lighting

General Specifications

Rated Input Voltage	200-240Vac,50/60Hz
Operating Input Voltage Range	180-264Vac,50/60Hz
Input Current	<0.07A @ 230Vac
Input Power (Typical)	12.8W
Power Factor	>0.95 @ 230Vac/Full Load
THD	<10% @ 230Vac/Full Load
Efficiency (Typical)	78% @ 230Vac/Full Load
Driver Type	Constant Current DALI 2.0
Output Current	350mA ±3%, 300mA ±3%, 275mA ±3%, 250mA ±3%, 225mA ±3%, 200mA ±3%, 175mA ±3%, 150mA ±3%, 125mA ±3%, 100mA ±3% *Refer DIP switch Table for O/P current selection
Output Voltage Range	6-42Vdc (6-42Vdc @ 275mA, 6-36Vdc @ 300mA, 6-30Vdc @ 350mA)
Output Power	10.5W
Number of Output Channels	1 Channel
Output Type	Class II
Dimming Controller Type	DALI 2.0
Ambient Operating Temperature Range	-10°C to 60°C
Max. Case Temperature	90°C
Input Surge Protection	2KV
Protections	Input Over Current : Non Resettable (Fuse) Output Short Circuit : Auto Recovery (HICCUP Mode) Output Open Circuit : Auto Recovery (HICCUP Mode) Output Overload : YES Over Temperature : Auto Recovery (HICCUP Mode)
Safety Standards	EN61347-1, EN61347-2-13, EN62384
Flicker-free standard	IEEE1789
Withstand Voltage	I/P-O/P:3750Vac, I/P DALI:500Vac
Leakage Current	<0.7mA @ 240Vac
Isolation resistance	I/P-O/P:100MΩ / 500Vdc / 25°C / 70% RH
Life	50,000 Hours @ Tc 80°C
Approvals / Class	SELV Equivalent
Warranty	3 Years
Weight	0.084 Kg

Note : Suitable for Indoor application only

Fulham extends a limited warranty only to the original purchaser or to the first user for a period of **03 years @ Tc 80°C** from the date of manufacture when properly installed and operated under normal conditions of use. For complete terms and conditions, please reference the Fulham Product Catalog (www.fulham.com). Due to a program of continuous improvement, Fulham reserves the right to make modifications or variations in design or construction to the equipment described. © Fulham Company Limited, All Rights Reserved.

DIP Switch Chart :

Remark: ★ this current is factory default.
 - this Switch is off.

Pin(W) typ.	Output			Switch			
	Prated(w)	Irated(mA)	Voltage(Vdc)	1	2	3	4
9.80	4.20	100	6-42	-	ON	ON	ON
11.3	5.25	125	6-42	ON	-	ON	ON
12.8	6.30	150	6-42	-	-	ON	ON
14.3	7.35	175	6-42	-	ON	-	ON
15.8	8.40	200	6-42	-	-	-	ON
17.2	9.45	225	6-42	ON	ON	ON	-
18.7	10.5	250	6-42	-	-	ON	-
21.6	11.0	275	6-42	-	ON	-	-
24.6	10.8	300	6-36	ON	-	-	-
25.7	10.5	350 ★	6-30	-	-	-	-

Before use, always check dipswitch settings

THD vs. Load

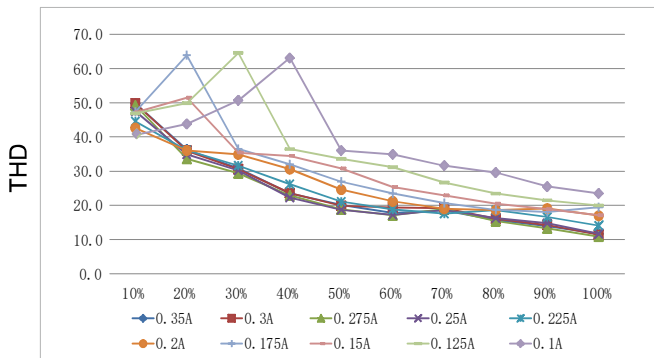

Load

Power factor vs. Load

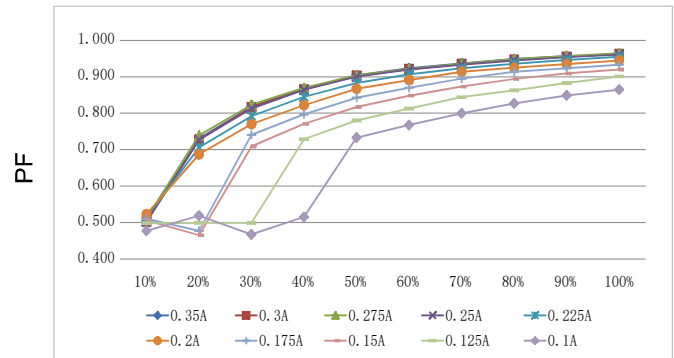

Load

Efficiency vs. Load

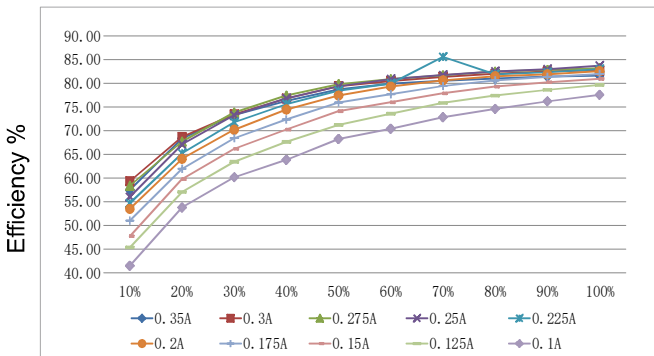

Load

Lifetime vs. case temperature

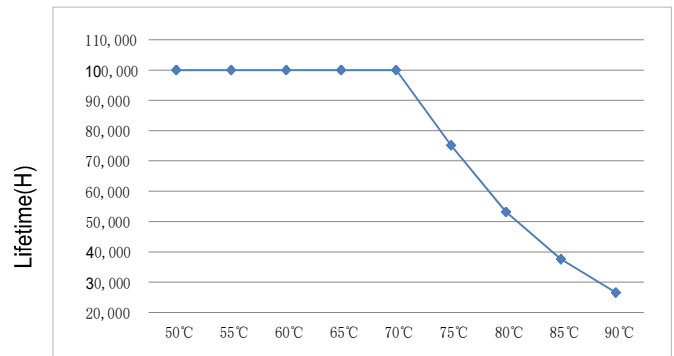

case temperature(Tc)

Fulham extends a limited warranty only to the original purchaser or to the first user for a period of **03 years @ Tc 80°C** from the date of manufacture when properly installed and operated under normal conditions of use. For complete terms and conditions, please reference the Fulham Product Catalog (www.fulham.com). Due to a program of continuous improvement, Fulham reserves the right to make modifications or variations in design or construction to the equipment described. © Fulham Company Limited, All Rights Reserved.

DALI dimming application

Wiring diagram

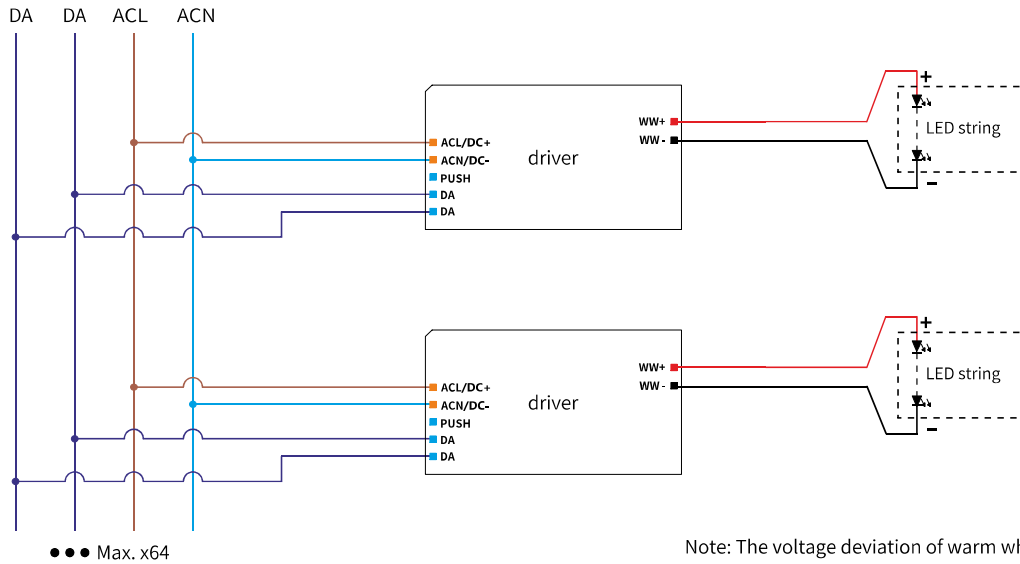

Note: The voltage deviation of warm white and cool white light strings should be less than 0.5V

Activating DALI control mode

- After installation according to the wiring diagram of DALI control application, the driver will automatically switch to the DALI control mode after receiving any DALI command.

Remarks:

- Standard DALI control line voltage range: 9.5V to 22.5V, type 16V.
- The two DALI control lines polarity-reversible.
- Max. 64 DALI drivers per DALI control line.
- The maximum distance length of the DALI control line is 300m at 2 × 1.5mm².
- DALI bus can be wired together with any mains voltage cables, but separate wiring is recommended.

Wiring distance vs cable size

Cable size	Distance
2 × 0.50mm ²	max. 100m
2 × 0.75mm ²	max. 150m
2 × 1.00mm ²	max. 200m
≥ 2 × 1.50mm ²	max. 300m

Dimming curve

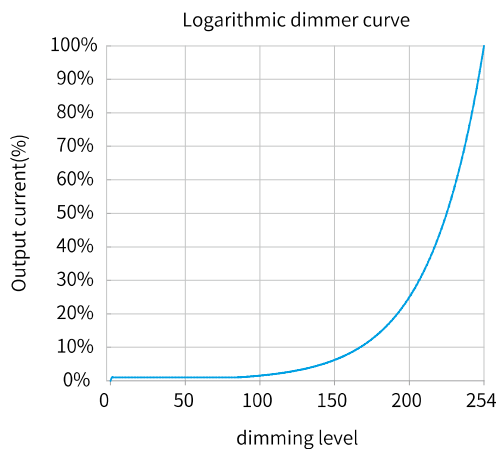

Remarks: The dimming curve can be selected by DALI configuration. The default is logarithmic dimming curve.

Fulham extends a limited warranty only to the original purchaser or to the first user for a period of **03 years @ Tc 80°C** from the date of manufacture when properly installed and operated under normal conditions of use. For complete terms and conditions, please reference the Fulham Product Catalog (www.fulham.com). Due to a program of continuous improvement, Fulham reserves the right to make modifications or variations in design or construction to the equipment described. © Fulham Company Limited, All Rights Reserved.

PUSH dimming application

Wiring diagram

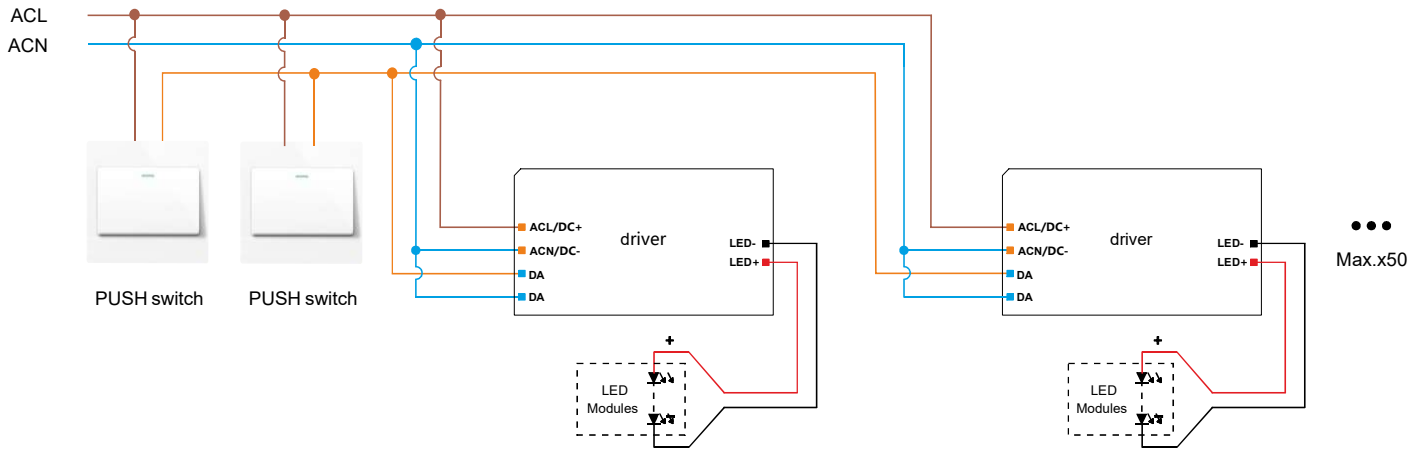

Activating PUSH control mode

- After installation according to the wiring diagram of PUSH dimming application, short press the PUSH switch 3 times within 3 seconds, the driver will automatically switch to PUSH dimming mode.

Remarks:

Max.50driversperPUSHcontrolline.

Turn on or turn off: short press push switch for 0.2-1s.

Dimming: long press push switch for 1-5s.

Power on status:

- After power on,the light state will be the same as the last dimming level.

- If the light is on before the power is turned on, after turning the power back on, the brightness will be the same as the last time.

- If the light is off before the power is turned off, the light will be turned off after the power is turned back on. You need to press the PUSH-DIM dimming switch for a short time to turn on the light. The brightness after lighting will be the same as the last time.

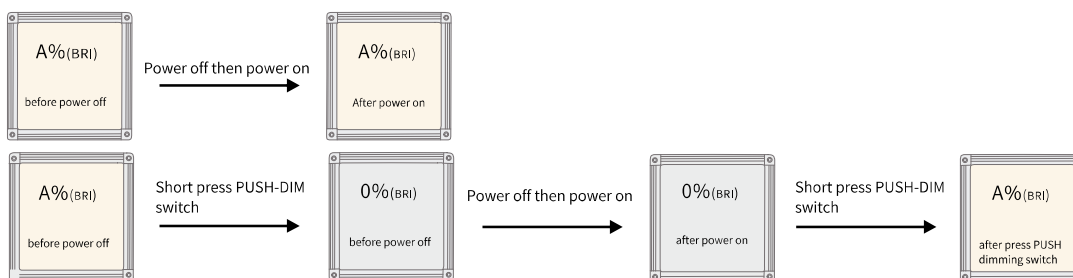

Multiple lights synchronize control operation

method 1: Step 1:long press the PUSH-DIM switch,confirm each light is on.

Step 2:short press the PUSH-DIM switch,confirm each light is off.

Step 3:long press the PUSH-DIM switch,confirm each light is from darkest to brightest and all the lights are synchronous.

method 2: - Long press the PUSH-DIM dimming switch for more than 15s, all drivers will output 100% brightness.

Fulham extends a limited warranty only to the original purchaser or to the first user for a period of **03 years @ Tc 80°C** from the date of manufacture when properly installed and operated under normal conditions of use. For complete terms and conditions, please reference the Fulham Product Catalog (www.fulham.com). Due to a program of continuous improvement, Fulham reserves the right to make modifications or variations in design or construction to the equipment described. © Fulham Company Limited, All Rights Reserved.

Mechanical Data :

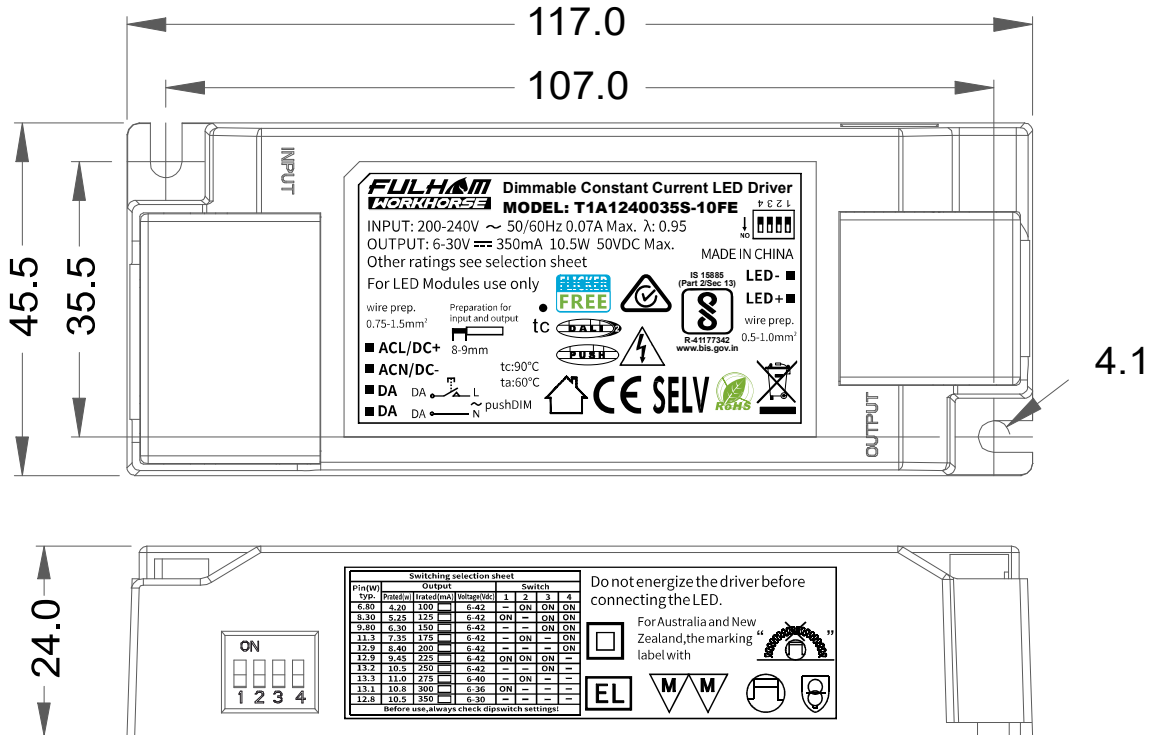

Note : All Dimensions are in mm.

Unit : mm
Tolerance=±0.5mm

Packaging

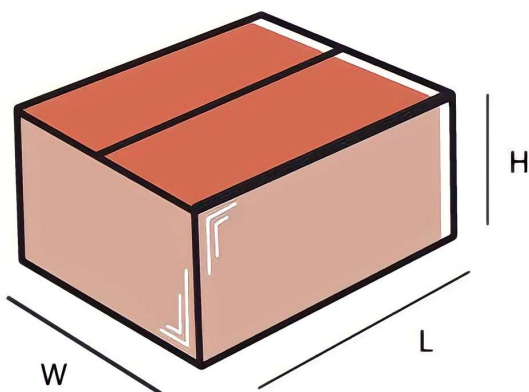

Master carton

OUTER DIMENSION		
L	W	H
450mm	350mm	180mm
Net Weight	Gross Weight	QUANTITY
6.5 kg	7.6 kg	72 pc.

Fulham extends a limited warranty only to the original purchaser or to the first user for a period of **03 years @ Tc 80°C** from the date of manufacture when properly installed and operated under normal conditions of use. For complete terms and conditions, please reference the Fulham Product Catalog (www.fulham.com). Due to a program of continuous improvement, Fulham reserves the right to make modifications or variations in design or construction to the equipment described. © Fulham Company Limited, All Rights Reserved.