

# FHSCP-UNV3-10W-L-SD-A-AP



RoHS  
COMPLIANT



## Emergency LED Driver

- Emergency LED Driver
- Universal Voltage: 100-347V~
- Output Voltage Range: 15-55V  $\overline{\text{---}}$
- Output Current: 667mA Max
- Output Wattage: 10W
- Output Type: LED Class 2
- Self-Diagnostic
- Dry and Damp Location

## General Specifications

Input Voltage / Frequency	100-347V~ , 50/60Hz
Input Current	<0. 1A
Input Power	<5W
Standby Power	0.85W
Input Power Pass-Through Rating (AC Driver Line)	3A
Max Output Rating (LED+ LED-	3A, 55V Max
Output Power	10W
Output Voltage Range	15-55V $\overline{\text{---}}$
Output Current Rated	0.667A Max
Number of Output Channels	1 Channel
Test Switch	Plastic Bi-Color Test Switch
Input Surge Protection	3KV/6KV Ring wave, 1KV/2KV Combine surge
Emergency Mode Protections	Output Open Protection Output Overload Protection Output Short Circuit Protection Output Temperature Protection
RFI/EMI	FCC Part 15 ClassA
Ambient Operating Temperature Range	0°C To 55 °C( 32 °F To 131 °F)
Tc	63.5°C( 146. 3 °F )
Sound Rating	A
Battery Type	Ternary lithium battery
Battery Voltage	10.95V
Battery Capacity	2600mAh
Battery Rating	28.47Wh
Battery Recharge Time	24 Hours
Battery Discharge Time	Min 1.5 Hours
IP Rating	IP20
Test Switch Remote Mounting Distance	65.6' (20m) Max.
Service Life	50,000 hours
Warranty	5 Years From the date of manufacture when properly installed
Safety Standards	UL 924/UL 1310/CSA C22.2 No.141

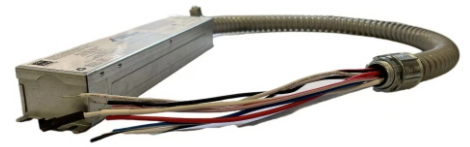

# FHSCP-UNV3-10W-L-SD-A-AP



RoHS COMPLIANT



## Mechanical Data

Overall Dimensions	
Length	9.646" [245mm]
Width	2.117" [55.3mm]
Height	1.339" [34mm]

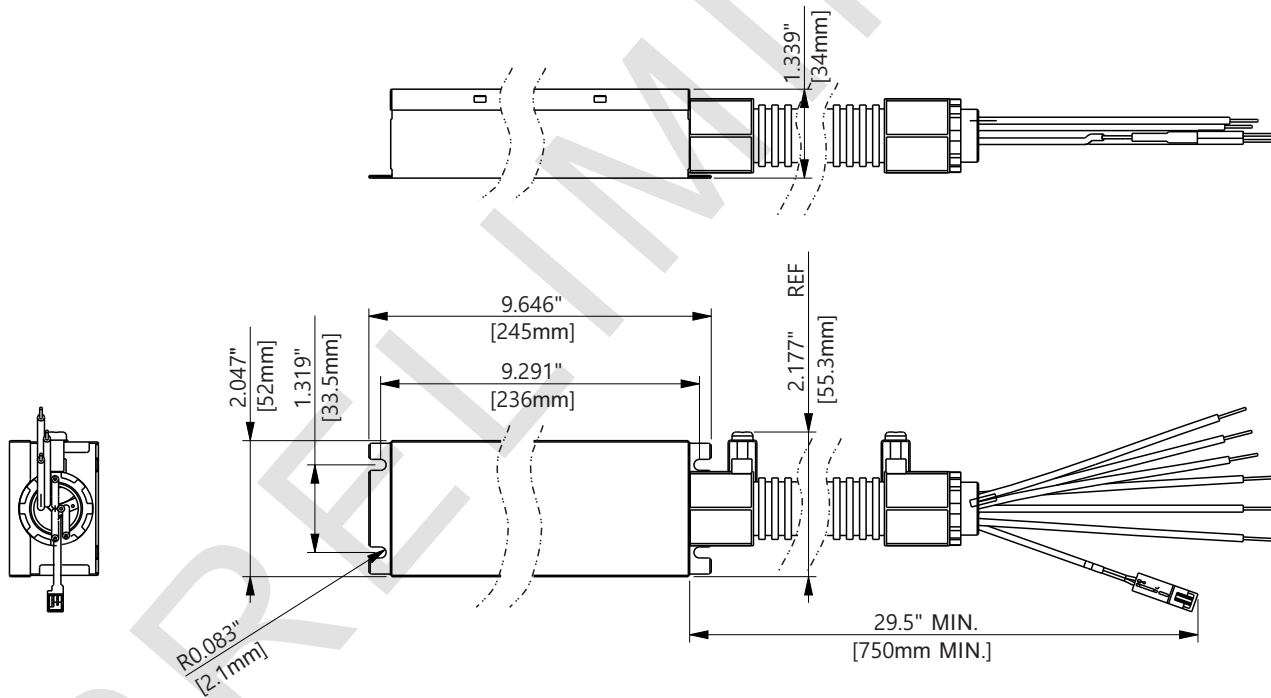

Tolerance=0.02"

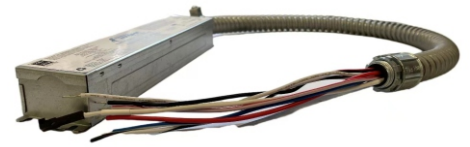

# FHSCP-UNV3-10W-L-SD-A-AP



RoHS COMPLIANT



## Accessories

### Test switch wire

Recommended to be used in the luminaire

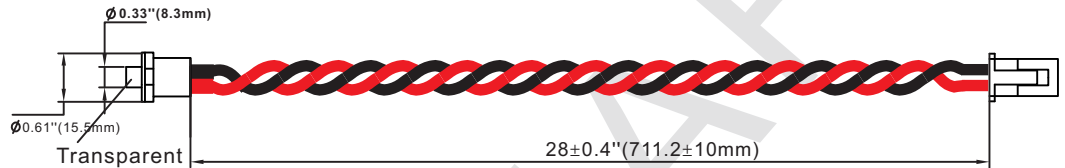

## Optional Accessories

### Bi-Color Wet Location Test Switch: FHS-TSTWL-BC

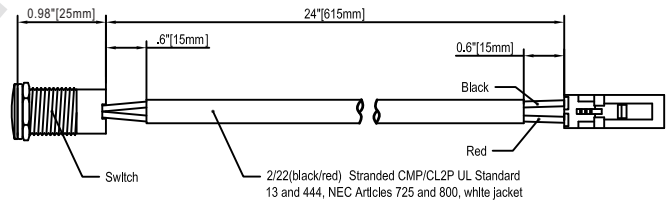

#### Overall Switch Dimension

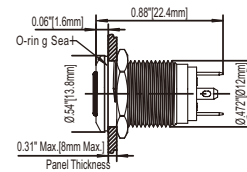
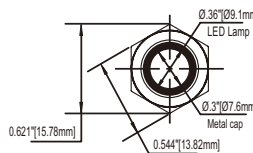

Mounting hole:  $\phi 0.472'' - 0.492''$   
[ $\phi 12\text{mm} - 12.5\text{mm}$ ]

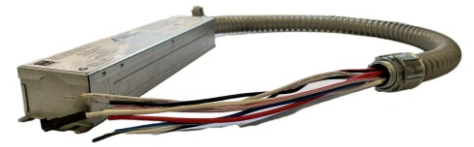

# FHSCP-UNV3-10W-L-SD-A-AP



RoHS COMPLIANT



## Optional Accessories

Wall Plate: FHSWLPWH



Wall plate and screw color:  
white with black lettering

Wall Plate: FHSWLPPWH(Pure White Wall Plate)

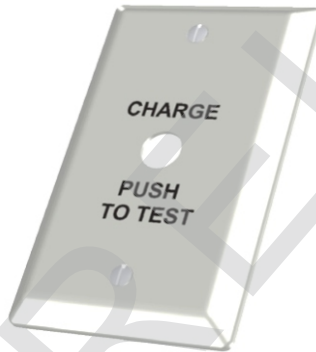

Wall plate and screw color:  
Pure white with black lettering

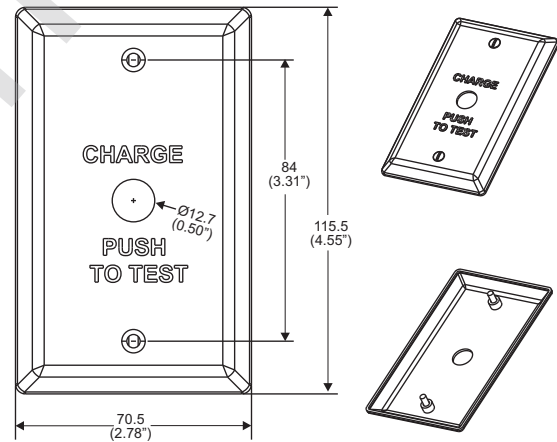

1. "Charge push to Test" plate
2. (2) 6-32 x 1/2" LG mounting screws



# FHSCP-UNV3-10W-L-SD-A-AP



RoHS COMPLIANT



## Wiring Diagram

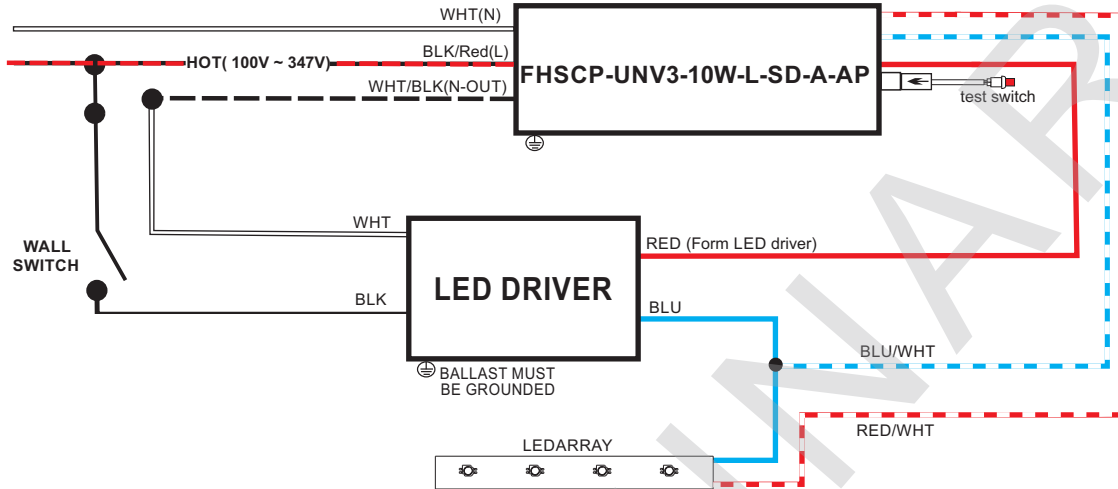

## Wiring Diagram (Emergency Only)

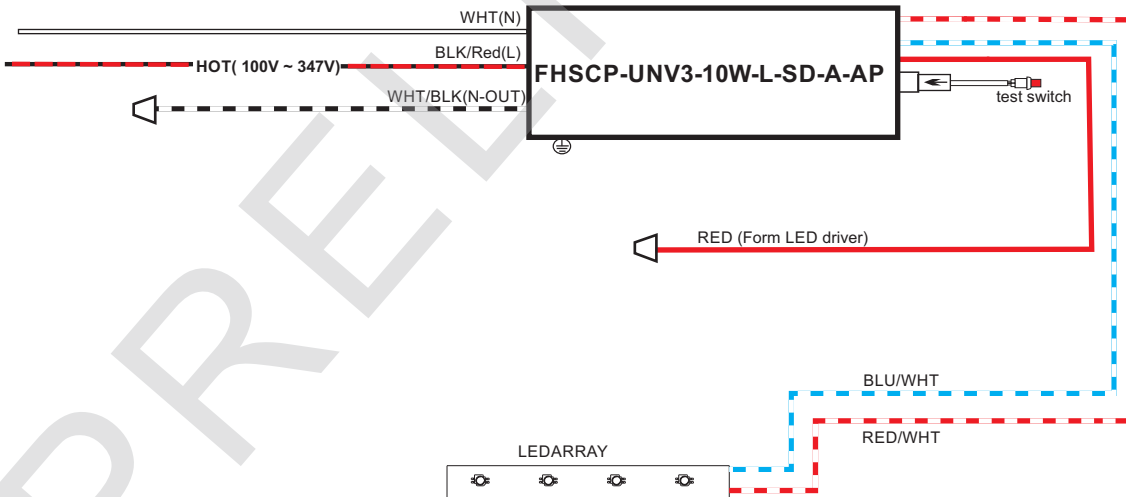

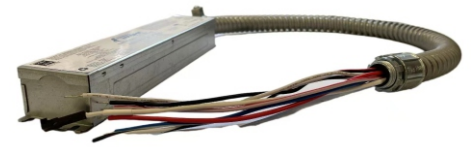

# FHSCP-UNV3-10W-L-SD-A-AP



RoHS  
COMPLIANT



## TEST SWITCH INDICATOR STATUS:

LED Indicators Status	EM Driver Status/Mode
● Solid Green	System OK/AC OK.
● Flashing (0.1s on/3s off)	Normal working in EM mode. (Including Self-test/self-diagnostic)
● Flashing (1s on/1s off)	Self-diagnose process ongoing.
● Flashing (2s on/0.5s off)	Self-diagnose enabled
● Flashing (0.5s on/2s off)	Self-diagnose disabled
● Flashing (4s on/1s off)	Battery PACK not found.(Including Self-test/self-diagnostic)
● Flashing (1s on/1s off)	Battery PACK fault. (Including Self-test/self-diagnostic)
● Solid Red	Over voltage protection. (Including Self-test/self-diagnostic)
● Solid Red	Over current protection. (Including Self-test/self-diagnostic)
● Flashing (0.1s on/3s off)	Self-diagnose process current fault or Battery voltage <87.5%.

### EM Test:

Press and hold the test button (>1s) to enter EM mode in normal AC powered.

### Manual Self-Diagnostic:

After charging twelve (12) hours at least, quickly press the test button three(3) times to force the controller to enter Self-Diagnostic cycle and discharge for 90 minutes. To quit the Self-Diagnostic cycle after engaged, press and hold the test button for three (3) seconds.

### Query Self-Diagnostic Status:

Fast click 2 times within 2s to query the Self-Diagnostic status. The indicator would blink for current status for 3 cycles. 2s ON/0.5s OFF stands for Enabled. 0.5s ON/2s OFF stands for Disabled.

### How to Enable and Disable Self-Diagnostic Status:

Press and hold the test button for one second, then release, and press and hold the test button for 2 seconds.

### Cancel reporting error:

In standby, press and hold the button for about 5s to cancel the error indication.

### Emergency Battery Disconnect:

Press and hold the test switch for 5 seconds during EM output condition to turn off EM output. This is useful for production environment to turn off the EM output once a luminaire has completed functionality testing.

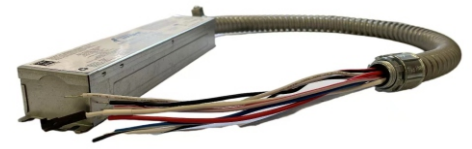

# FHSCP-UNV3-10W-L-SD-A-AP



RoHS  
COMPLIANT



## Guidelines

### Grounding

- Driver must be grounded by means of the Driver case.

### LED load

- Fulham's Hotspot Constant Power Emergency LED drivers are designed to drive passive LEDs, -COB's and -LED assemblies. Proper function is not guaranteed when (LED) loads with active components are used.

### Mounting / Cooling

- Above an output power of 10W, the driver needs to be mounted on a heat conductive surface of at least 40cm<sup>2</sup>. Always test if the surface is sufficient enough before installing the driver.

### Short-circuit protection

- In case of a short circuit the LED driver switches to protection mode. After the removal of the short-circuit the LED driver will Latch ,need restart AC Power.

### No-load Operation

- In no-load operation the output voltage will not exceed the specified open circuit output voltage.

### Hot Swapping

- This driver does not support hot swapping of the LEDs

### Battery Maintenance

- In order to maintain proper operation and warranty coverage, the battery must be recharged once per year prior to installation.

### Warranty

- Reference Fulham's limited Warranty: <https://cdn.fulham.com/PDFs/Limited-Warranty.pdf>

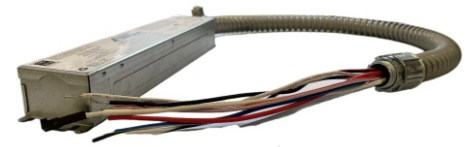

# FHSCP-UNV3-10W-L-SD-A-AP



RoHS COMPLIANT



## Part Number Matrix

**FHS** **CP** **UNV3** **10W** **L** **SD** **A** **AP**

LED Driver

Driver Type

Input Voltage

Power

Case Type

Special Features

Special Features

Special Features

FHS = FireHorse HotSpot Driver CP = Constant Power

UNV3 = 100V-347V

10W = 10 Watts

L = Long Case

SD = Self Diagnostic

A = Conduit

AP = Asia Pacific

## Product Image: LED Driver

FHSCP-UNV3-10W-L-SD-A-AP



## Packaging

Master Carton



OUTER DIMENSION		
L	W	H
Net Weight	Gross Weight	QUANTITY