



FHUPS1-UNV-50L-SD



GENERAL INSTALLATION GUIDELINES FOR LED EMERGENCY MICRO INVERTER

IMPORTANT SAFE PRACTICES

When using electrical equipment and this lighting device basic safety precaution should be followed at all times including but not limited to the following:

PLEASE READ CAREFULLY AND FOLLOW ALL INSTRUCTIONS FOR YOUR OWN SAFETY

IMPORTANT: Do not connect battery until fixture is installed.

IMPORTANT: An un-switched AC power source of 100VAC to 277VAC is required.

This device is designed for use in fixtures listed for dry and damp locations.

CAUTION: Make sure all electrical connections conform to the National Electrical Code and all applicable local regulations.

CAUTION: Do not let power supply cords touch hot surfaces.

CAUTION: Do not mount near gas or electric heaters.

CAUTION: Do not use outdoors.

CAUTION: Battery is rechargeable LiFePO4 type and must be recycled or disposed of properly. Do not use this emergency driver with accessory equipment other than recommended by manufacturer; failure to follow this may cause an unsafe condition. Servicing should only be performed by qualified service personnel. Do not use this emergency driver for other than intended use.

CAUTION: Equipment should be mounted in locations and at heights where it will not readily be subjected to tampering by unauthorized personnel.

CAUTION: For use with a metal enclosed wiring system.

IMPORTANT: The output EM power will be the maximum of connected battery unless programmed to a lesser value. EM output power will not exceed the battery rating.

IMPORTANT: Indicator (LED light) illuminated indicates battery in charge mode when AC power is applied.

It is recommended and required by applicable code to test emergency function to ensure proper operation of the system; push the test switch for sixty (60) seconds every 30 days to ensure the emergency driver is functioning as LED light source illuminated. Conduct a ninety minute (90) discharge test one time (1) per year; LED light source should be illuminated for a minimum of ninety minutes (90).

ASSEMBLY and FIELD INSTALLATION WIRING: WARNING: AC power must be off before proceeding with assembly or installation of emergency driver.

TESTING SYSTEM: The emergency battery requires a charge minimum of one (1) hour before testing the circuit. A full charge requires twelve (12) hours (Refer to battery chart).

IMPORTANT: In order to maintain proper operation and warranty coverage, the battery must be recharged once per year prior to installation.

Fulham Head Quarters:
Fulham Co., Inc
12705 South Van Ness Ave.
Hawthorne, CA 90250

SAVE THESE INSTRUCTIONS



FHUPS1-UNV-50L-SD



Wiring Diagram 1

For Luminaire(s) with an output power less than 50W (100VA) and Non 0-10 dimming function.

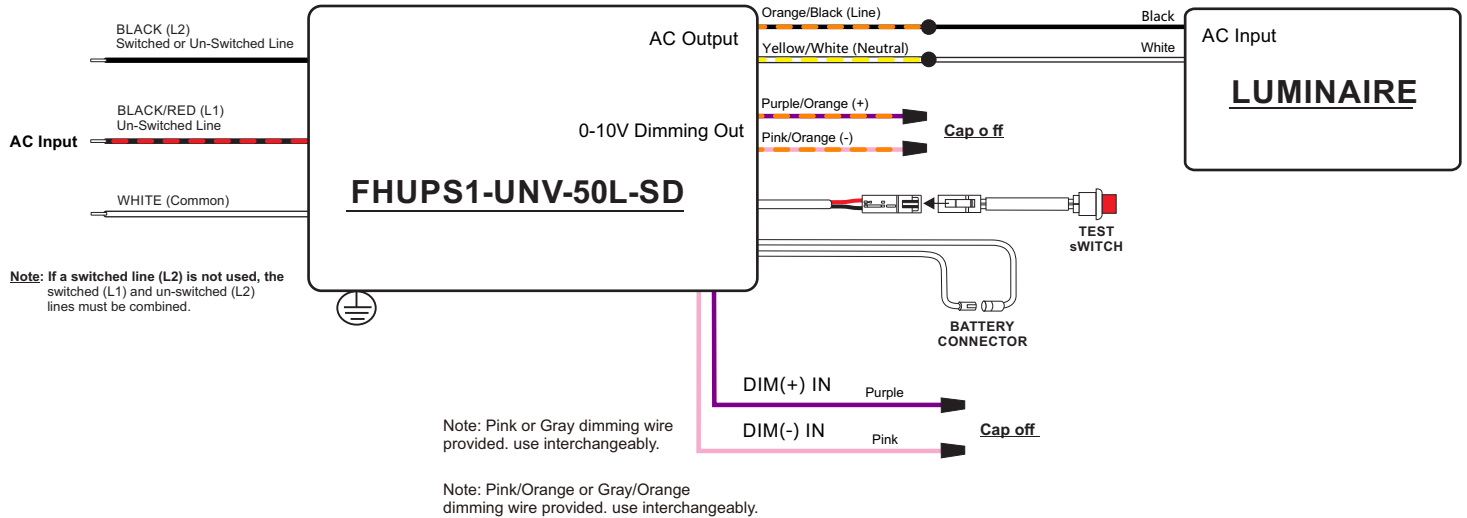

Wiring Diagram 2

For Luminaire(s) with an output power less than 320W (400VA) and have 0-10 dimming function.

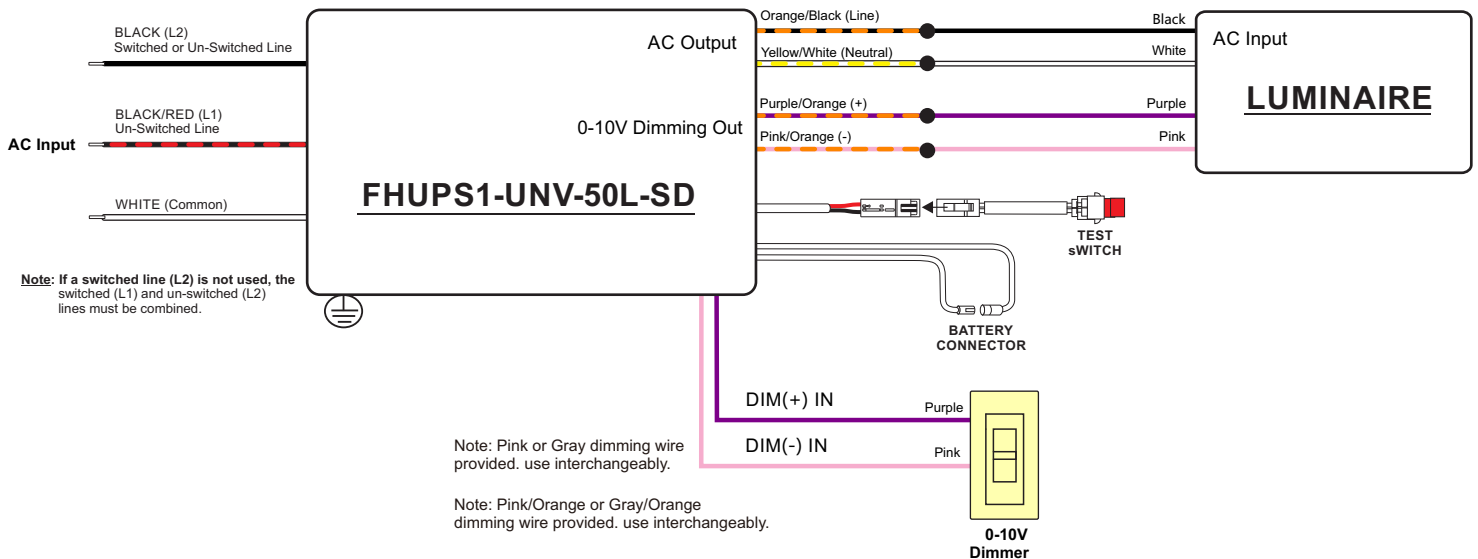



FHUPS1-UNV-50L-SD

IP20

Wiring Diagram 3

For Luminaire(s) with an output power less than 320W and 0-10 dimming function but 0-10V dimming is not used during normal operation.

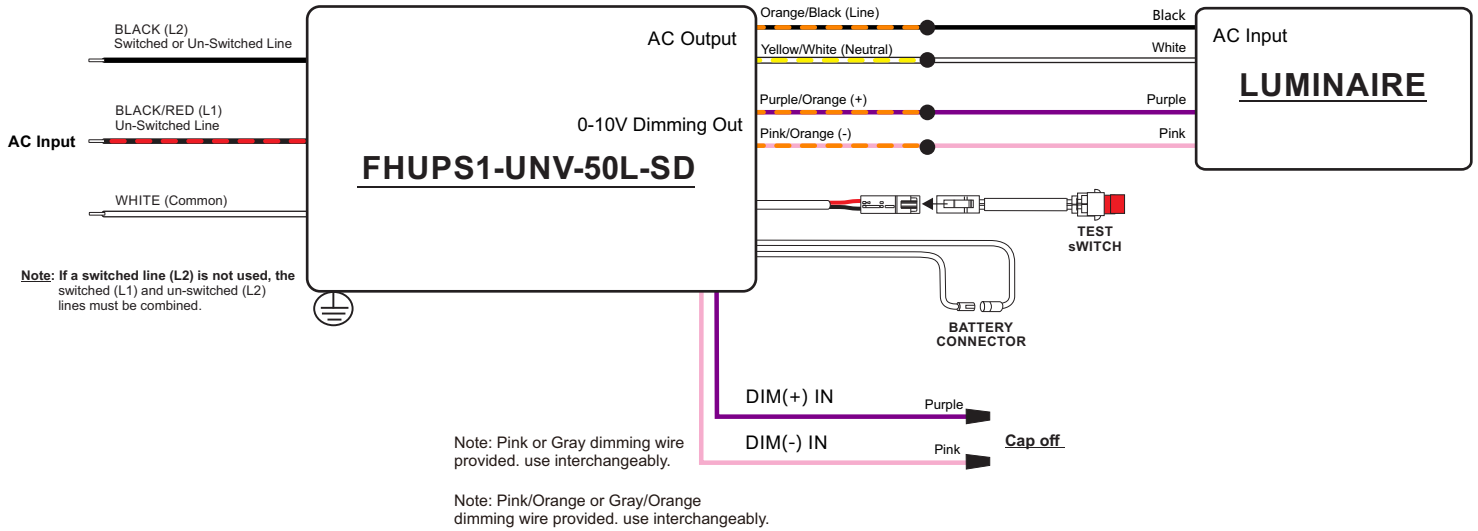



FHUPS1-UNV-50L-SD



Wiring Diagram 4

Wiring one single luminaire without 0-10V dimming

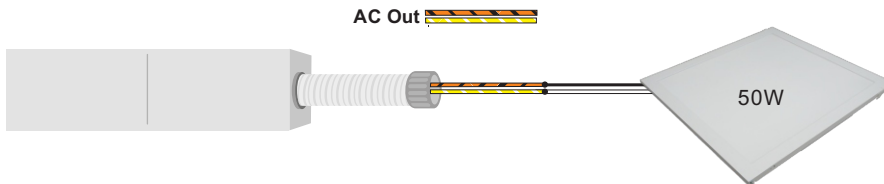

- One 50W luminaire powered at 100% during emergency

Wiring Diagram 5

Wiring multiple luminaires without 0-10V dimming

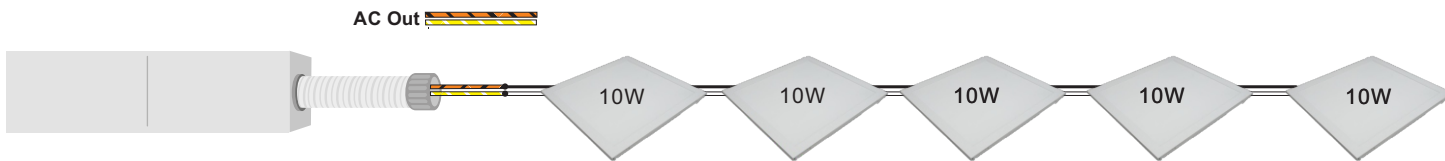

- Five 10W luminaires powered at 10W each during emergency

Wiring Diagram 6

Wiring multiple luminaires with 0-10V dimming

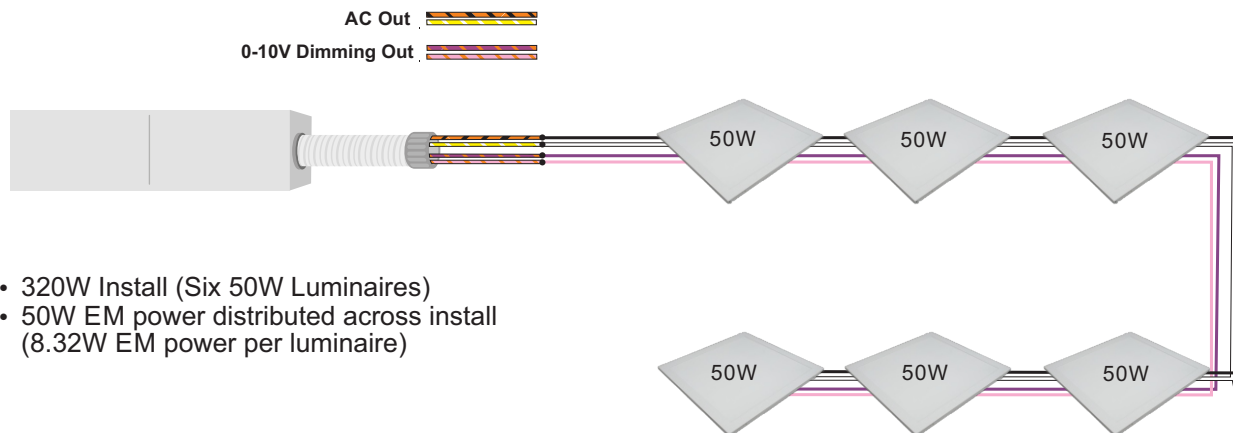

- 320W Install (Six 50W Luminaires)
- 50W EM power distributed across install (8.32W EM power per luminaire)



FHUPS1-UNV-50L-SD



TEST SWITCH INDICATOR STATUS:

LED Indicator Status	EM Driver Status/Mode
● Solid Green	System OK/AC OK(Self-diagnostic Enabled or Disabled)
● Slow Flashing Red, 4s on/1s off	Battery not detected, check battery switch or connection.
● Flashing Red, 1s on/1s off	Battery short circuit.
● Flashing Green, 2s on/2s off	Self-diagnostic test underway.
● Flashing Red, 0.5s on/2s off	Over power fault.
● Flashing Red, 0.5s on/3s off	In self-diagnostic mode. Battery voltage/power is abnormal.
● Flashing Green, 2.5s on/0.5s off	Self-diagnostic enabled.
● Flashing Green, 0.5s on/2.5s off	Self-diagnostic disabled.

*Notes: OTP= OverTemperature Protection; ensures max temperature ratings are not exceeded. .

TEST SWITCH OPERATIONS:

1.EM Test: Press and hold the test button (>1s) to enter EM mode in normal AC powered.

2.Manual Self-Diagnostic:Battery voltage greater than 20.4V ,or change for 12 hours. Quickly press the test button three times within three seconds to force the controller enter a Self-Diagnostic cycle.To quit the self-diagnostic cycle after engaged press and hold the test button for three seconds.

3.Enable/Disable Auto Self-Diagnostic: Press and hold the test button for two seconds, then release and quickly press the test button two times, then release and press and hold the test button for two more seconds. When properly executed the indicator on the test button will display the appropriate Enable/Disable status.Aflashing of 2.5s ON/0.5s OFF means“Enabled”, while a flashing of 0.5s ON/2.5s OFF means“Disabled”. Once Enable/Disable is set the status color on the test button will remain the same throughout normal operation (refer to Indicator StatusTable).

Check the current status: Press the button twice within 2 seconds. If the LED Indicator Status is 2.5s on/0.5s off, the current state is enabled. If the LED Indicator Status is 0.5s on/2.5s off, the current status is self-diagnostic disabled.

Self-diagnostic settings: Press the test button once quickly. Then release and then press and hold the test button for 2s and then release

Emergency Battery Disconnect:

Press and hold the test switch for 5 seconds during EM output condition to turn off EM output. This is useful for production environment to turn off the EM output once a luminaire has completed functionality testing.



FHUPS1-UNV-50L-SD



Programming:

The FHUPS1-UNV-50L-SD is programmed through the program wire on the emergency driver with the TPSB-100 programmer. Unless otherwise programmed the output will self-program to the maximum rating of the battery. Customer must use the programming harness and programming block that comes with the TPSB-100.

Programming Wire Diagram

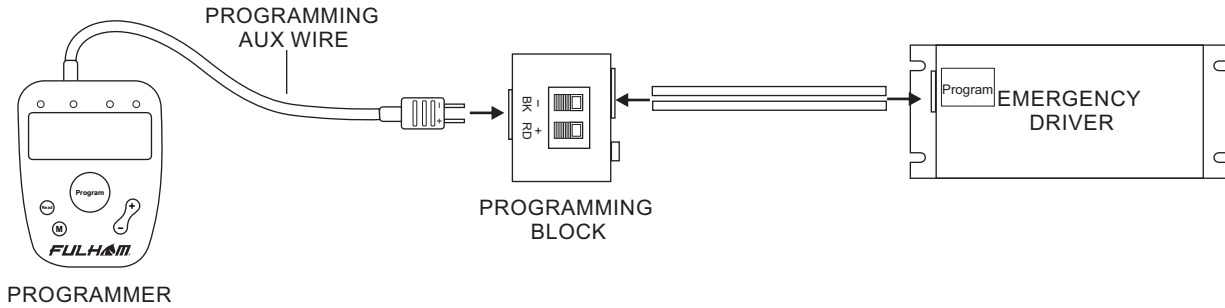

Programming Features

- Output EM Power
- * Enable / Disable Self-Diagnostic



SmartSet Software



TPSB-100 SmartSet Controller

* For more detailed programming instructions please see our Programming Instructions and Design Guide found on our website:

- <https://www.fulham.com/PDFs/SpecSheets/Fulham-Design-Guide-Programmable-Drivers.pdf>