



SPECIFICATION SHEET : TCD11200650-18C

This Is An Original Product From Fulham Co., Inc.

Description: Independent direct current power supply. High efficiency and reduced weight and size. Constant output current; Dimming

This Driver Will Operate The Following Led Lamps:
High Power LED up to 650mA. Max. Output Power 18W

ELECTRICAL DATA

INPUT VOLT: 120V ± 10%. 50/60Hz	120VAC
POWER FACTOR	>0.90% at Full Load without Dimmer
THD	<20%
EFFICIENCY	>70% with Full Load
SURGE PROTECTION	Yes
CURRENT PROTECTION	Yes
LED TYPES OPERATED	3W LED
NUMBER OF LEDS	4,5, or 6 in Series
CONSTANT CURRENT, VOLTAGES OR POWER	Constant Current
OUTPUT CURRENT	650mA
OUTPUT VOLTAGE	<30V
OUTPUT SHORT CIRCUIT PROTECTION	Yes
OUTPUT OPEN CIRCUIT PROTECTION	Yes
OUTPUT TO GROUND SHORT PROTECTION	Yes
OVERLOAD PROTECTION	Yes
MAX. CASE HOT SPOT TEMPERATURE	75° C
MIN. LAMP STARTING TEMPERATURE	- 20° C
MAX. POSSIBLE AMBIENT TEMPERATURE	45° C
THERMAL PROTECTION	Class P
SERVICE LIFE	50,000 Hours
DIMMING RANGE	100% ~ 10% (Output Power 1.5W)
DIMMING CONTROLLER TYPE	Triac Phase Control Dimmer

MECHANICAL DATA

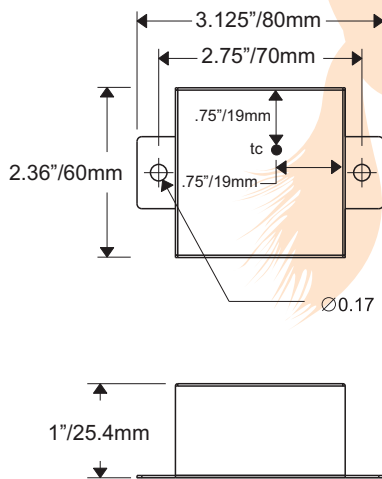

WHERE : L = Length, W = Width, H = Height

WIRING DIAGRAMS

WIRE LENGTH - INCHES	BLACK	WHITE	RED	BLUE		
	12" +/- 1"	12" +/- 1"	12" +/- 1"	12" +/- 1"		

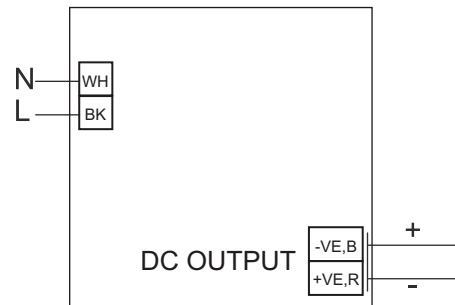

NOTE : This Ballast Case Must Be Grounded

Fulham extends a limited warranty only to the original purchaser or to the first user for a period of 5 years from the date of manufacture when properly installed and operated under normal conditions of use. For complete terms and conditions, please reference the Fulham product catalog (www.fulham.com)
Due to a program of continuous improvement, Fulham reserves the right to make modifications or variations in design or construction to the equipment described.